



# سازوکار



کاتالوگ  
محصولات  
سی‌ام‌تی



**CMT** ORANGE  
TOOLS®







# سازوکار

شرکت سازوکار با در نظر گرفتن نیاز فعالان در صنایع گوناگون و به پشتوانه هزاران مشتری، همچنین نزدیک به دو دهه تجربه در حوزه واردات و فروش ماشین‌آلات، ابزار و یراق‌آلات درصدد برآمده تا پلتفرمی برای کسب اطلاعات جامع و به روز، همراه با مشاوره تخصصی رایگان برای انتخاب محصولات ارائه نماید.

مزیت‌های رقابتی سازوکار از مهم‌ترین مزیت‌های رقابتی ساز و کار ضمانت اصالت کالا، گارانتی اختصاصی سازوکار، بسته‌بندی اختصاصی کالا، سرعت در تحویل و تامین محصولات با همکاری نمایندگان سراسر کشور و برترین فروشگاه‌های مجازی در عرصه تجارت الکترونیک می‌باشد.



مشخصات عاملیت فروش

۱-۱۴		۱	تیغ آره Saw Blades
۱۵-۵۳		۲	تیغ اُورفِرِز و سی ان سی Router Bits & Set
۵۴-۷۶		۳	توپی ها Tools with Bore & Kinves
۷۷-۸۳		۴	مته ها Industrial Dowel Drills
۸۴-۸۷		۵	تیغ آره عمودبُر Jig Saw Blades
۸۸-۹۰		۶	ابزارآلات برقی Power Tools
۹۱-۹۹		۷	متعلقات و دیگر محصولات Accessories

# تیغ آره

## Saw Blades

۱	تیغ آره MDF بُر
۲	آره ملامینه بُر
۲-۴	تیغ آره چوب بُر
۵	آره شکاری
۶	تیغ آره جنرال
۷	خطزن تک
۸	خطزن دوتکه
۹	آره پنل بُر
۹	خطزن پنل بُر
۱۰	آره شیارزن متغیر
۱۱	آره آلومینیوم بُر
۱۲	آره تیز بُر
۱۲	آره کورین
۱۳	بر آره پلکسی گلس بُر
۱۳	آره آهن بُر
۱۴	آره شیارزن - آره روکش سرامیک



281

تیغ آره MDF

Low Noise & Chrome Coated Saw Blades with TCG Grind



FILLED SLOTS



تخته چندلایه

ملامینه دو طرفه

درجه کیفی خوب

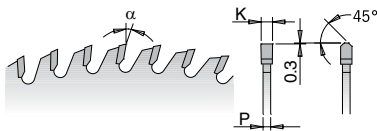

قطر	شفت	تعداد دندانه	ضخامت الماسه	ضخامت بدنه	زاویه الماسه	کد سفارش
D mm	B mm	Z	K mm	P mm	$\alpha$	ORDER NO
250	30	80	3,2	2,2	5°	281.680.10m کروم
300	30	96	3,2	2,2	5°	281.696.12M کروم
350	30	108	3,5	2,5	5°	281.708.14m کروم

281

تیغ آره MDF

Laminated & Chipboard Saw Blades Industrial Line



ملامینه دو طرفه

برش عمود بر تخته چندلایه

درجه کیفی عالی

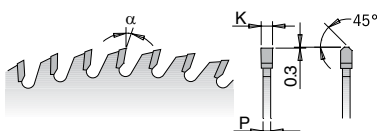

قطر	شفت	تعداد دندانه	ضخامت الماسه	ضخامت بدنه	زاویه الماسه	کد سفارش
D mm	B mm	Z	K mm	P mm	$\alpha$	ORDER NO
180	30	56	3,2	2,2	10°	S281.03489
250	30	80	3,2	2,2	10°	281.080.10m
300	30	96	3,2	2,2	10°	281.096.12m
350	30	108	3,5	2,5	10°	281.108.14m



## 1. Saw Blades

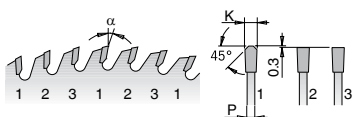

### 295

### آره ملامینه بر

Melamine & Laminated Long-Lasting Saw Blades XTreme Line



قطر	شفت	تعداد دندانه	ضخامت الماسه	ضخامت بدنه	زاویه الماسه	کد سفارش
D mm	B mm	Z	K mm	P mm	$\alpha$	ORDER NO
300	30	96	3,2	2,2	10°	295.096.12m

### 285

### تیغ آره چوب بر

Low Noise & Chrome Coated Saw Blades with ATB Grind

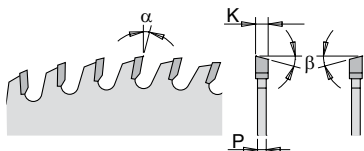

FILLED SLOTS



قطر	شفت	تعداد دندانه	ضخامت الماسه	ضخامت بدنه	زاویه الماسه	کد سفارش
D mm	B mm	Z	K mm	P mm	$\alpha$	ORDER NO
250	30	40	3,2	2,2	15°	285.640.10m کروم
250	30	60	3,2	2,2	10°	285.660.10m کروم
300	30	48	3,2	2,2	15°	285.648.12m کروم
300	30	72	3,2	2,2	10°	285.672.12m کروم
350	30	54	3,5	2,5	15°	285.654.14m کروم

285

تیغ آره چوب‌بر

Rip & Crosscut Saw Blades Industrial Line

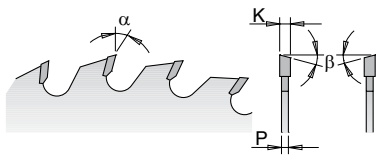

قطر	شفت	تعداد دندان	ضخامت الماسه	ضخامت بدنه	زاویه الماسه	کد سفارش
D mm	B mm	Z	K mm	P mm	$\alpha$	ORDER NO
250	30	40	3,2	2,2	15°	285.040.10m
250	30	60	3,2	2,2	10°	285.060.10m
300	30	48	3,2	2,2	15°	285.048.12m
300	30	72	3,2	2,2	10°	285.072.12m
300	30	60	3,2	2,2	15°	285.060.12m
350	30	72	3,5	2,5	15°	285.072.14m
350	30	84	3,5	2,5	10°	285.084.14m
400	30	60	3,5	2,5	10°	285.060.16m

286-290-293 تیغ آره چوب‌بر (دندان کوسه‌ای)

Rip Saw Blades Industrial Line

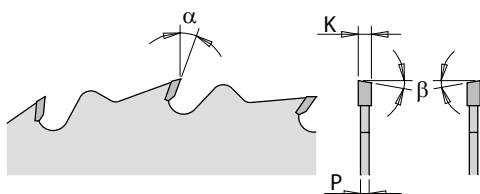

قطر	شفت	تعداد دندان	ضخامت الماسه	ضخامت بدنه	زاویه الماسه	کد سفارش
D mm	B mm	Z	K mm	P mm	$\alpha$	ORDER NO
250	30	24	2,8	1,8	20°	290.250.24m
300	30	48	3,2	2,2	15°	286.048.12m
315	30	28	3,2	2,2	20°	293.028.12m

271

تیغ آره چوب بر روکش سرامیک

ITK-Plus® Rip & Crosscut Saw Blades



درجه کیفی عالی



درجه کیفی خوب

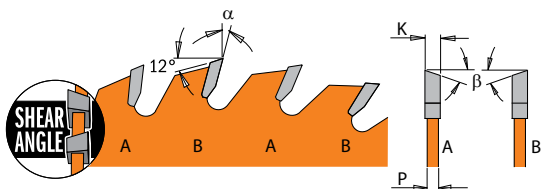

قطر	شفت	تعداد دندانه	ضخامت الماسه	ضخامت بدنه	زاویه الماسه	کد سفارش
D mm	B mm	Z	K mm	P mm	$\alpha$	ORDER NO
165	30	24	1,7	1,1	18°	271.165.24m
200	30	36	1,8	1,2	15°	271.200.36m
216	30	36	1,8	1,2	-5°	271.216.36m
235	30 (+25)	36	2,4	1,6	18°	271.235.36m

272

تیغ آره چوب بر

ITK-Plus™ Crosscut Saw Blades



برش عمودی چوب

درجه کیفی عالی

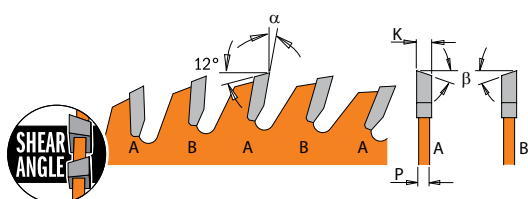

قطر	شفت	تعداد دندانه	ضخامت الماسه	ضخامت بدنه	زاویه الماسه	کد سفارش
D mm	B mm	Z	K mm	P mm	$\alpha$	ORDER NO
184	30	40	1,7	1,1	18°	272.184.40m
200	30	48	1,8	1,2	15°	272.200.48m
216	30	48	1,8	1,2	-5°	272.216.48m
235	30 (+25)	48	2,4	1,6	18°	272.235.48m
250	30	60	2,4	1,6	15°	272.250.60m



277

تیغ آره شکاری

Thick-Kerf Multi-Rip Saw Blades with Rakers Industrial Line

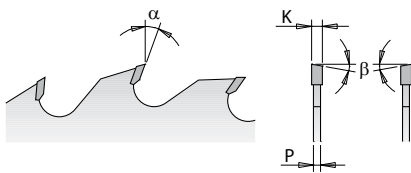

قطر	شفت	تعداد دندانه	ضخامت الماسه	ضخامت بدنه	زاویه الماسه	کد سفارش
D mm	B mm	Z	K mm	P mm	$\alpha$	ORDER NO
300	30	24+4	4,0	2,8	18°	277.024.12m

278

تیغ آره چوب‌ر (دندانه کوسه‌ای)

Multi-Rip Anti-Kickback Saw Blades Industrial Line

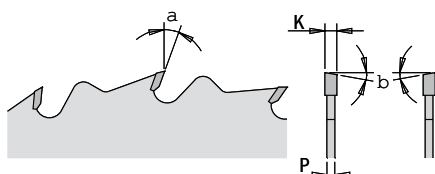

قطر	شفت	تعداد دندانه	ضخامت الماسه	ضخامت بدنه	زاویه الماسه	کد سفارش
D mm	B mm	Z	K mm	P mm	$\alpha$	ORDER NO
300	30	28	3,2	2,2	18°	278.028.12M
300	30	28	3,2	2,2	18°	278.036.14M



292

تیغ آره جنرال بُر

Fine Cut-Off Saw Blades for Portable Machines

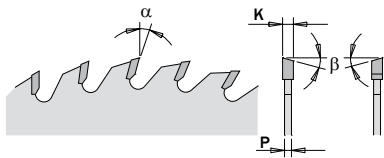

قطر	شفت	تعداد دندانها	ضخامت الماسه	ضخامت بدنه	زاویه الماسه	کد سفارش
D mm	B mm	Z	K mm	P mm	α	ORDER NO
216	30	64	2,8	1,8	-5° Neg	292.216.64m

285

تیغ آره جنرال بُر

Finishing Saw Blades Industrial Line

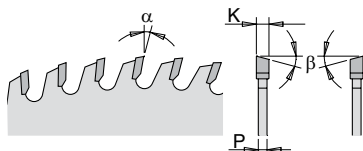

قطر	شفت	تعداد دندانها	ضخامت الماسه	ضخامت بدنه	زاویه الماسه	کد سفارش
D mm	B mm	Z	K mm	P mm	α	ORDER NO
180	30	56	3.2	2.2	5°	285.056.07M
250	30	80	3.2	2.2	5°	285.080.10M
300	30	96	3.2	2.2	5°	285.096.12M
350	30	108	3.5	2.5	5°	285.108.14M
400	30	96	3.5	2.5	10°	285.096.16M
400	30	120	3.5	2.5	10°	285.120.16M

288

خطزن تک

Industrial Chrome-Coated Scoring Blades



ORANGE CHROME®

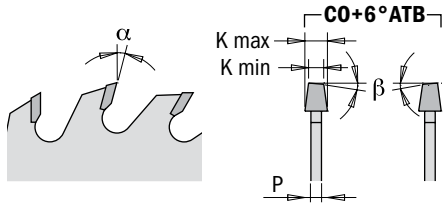

قطر	شفت	تعداد دندانه	ضخامت الماسه	ضخامت بدنه	زاویه الماسه	کد سفارش
D mm	B mm	Z	K mm	P mm	$\alpha$	ORDER NO
120	20	24	3,1-4,3	2,2	0°	288.720.24h
120	22	24	3,1-4,3	2,2	0°	288.720.24k
125	20	24	3,1-4,3	2,2	0°	288.725.24h

288

خطزن تک

Conical Scoring Blades Industrial Line

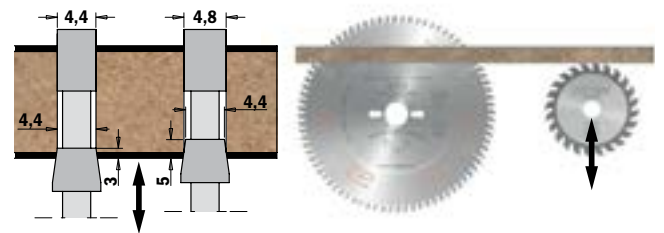
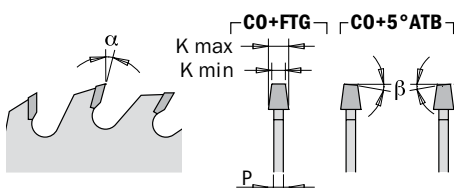

قطر	شفت	تعداد دندانه	ضخامت الماسه	ضخامت بدنه	زاویه الماسه	کد سفارش
D mm	B mm	Z	K mm	P mm	$\alpha$	ORDER NO
120	20	24	3,1-4,0	2,5	5°	288.120.24h
120	22	24	3,1-4,0	2,5	5°	288.120.24k
125	20	24	3,1-4,0	2,5	5°	288.125.24h



## 289

### خطزن دو تکه

Adjustable Scoring Blades Industrial Line

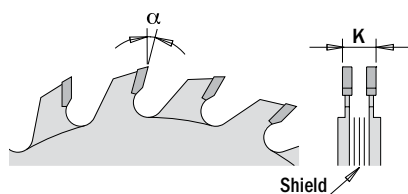

قطر	شفت	تعداد دندانه	ضخامت الماسه	ضخامت بدنه	زاویه الماسه	کد سفارش
D mm	B mm	Z	K mm	P mm	$\alpha$	ORDER NO
120	20	12+12	2,8-3,6	-	12°	289.120.24h
120	22	12+12	2,8-3,6	-	12°	289.120.24k
125	20	12+12	2,8-3,6	-	12°	289.125.24h

## 289

### خطزن دو تکه

Industrial Chrome-Coated Adjustable Scoring Blades

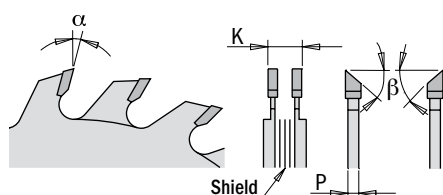

قطر	شفت	تعداد دندانه	ضخامت الماسه	ضخامت بدنه	زاویه الماسه	کد سفارش
D mm	B mm	Z	K mm	P mm	$\alpha$	ORDER NO
120	20	12+12	2,8-3,6	-	11°	289.720.24h
120	22	12+12	2,8-3,6	-	11°	289.720.24k

282

آره پنل بر

Panel Sizing Saw Blades Industrial Line

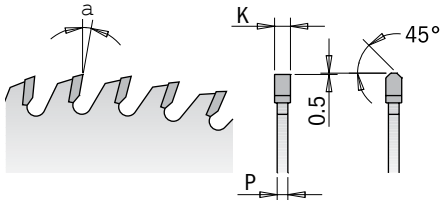

قطر	شفت	تعداد دندانه	ضخامت الماسه	ضخامت بدنه	زاویه الماسه	کد سفارش
D mm	B mm	Z	K mm	P mm	$\alpha$	ORDER NO
350	30	72	4,4	3,2	16°	282.072.14m
320	65	72	4,4	3,2	16°	282.072.13j
400	75	72	4,4	3,2	16°	282.072.16x

288

خطزن پنل بر

Conical Scoring Blades Industrial Line

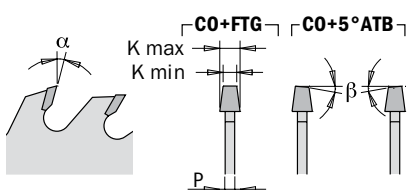
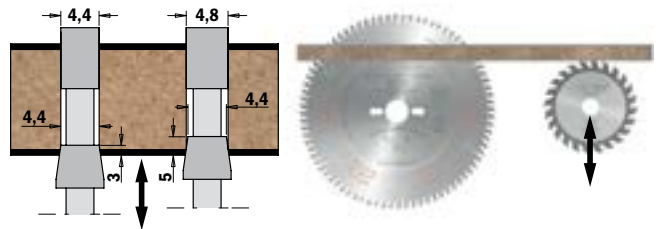

قطر	شفت	تعداد دندانه	ضخامت الماسه	ضخامت بدنه	زاویه الماسه	کد سفارش
D mm	B mm	Z	K mm	P mm	$\alpha$	ORDER NO
200	65	36	4,4-5,3	3,2	10°	288.200.36j



# 1. Saw Blades

## 230

## آره شیارزن متغیر

### Dado Saw Blades



این پکیج شامل تیغه‌های زیر می‌باشد

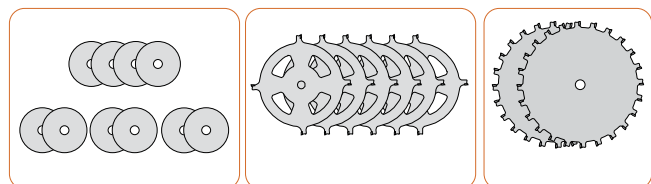

ست فیلر

دارای ۶ تیغ  
میانی ۴ الماسه

۲ عدد تیغ

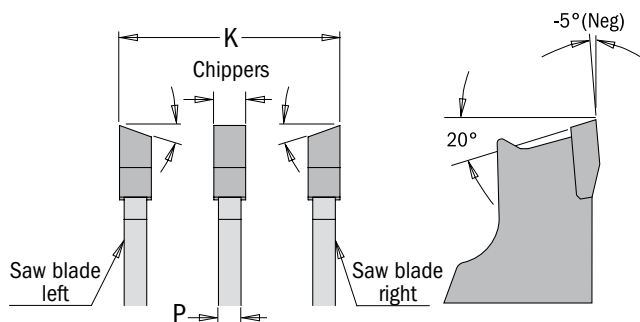

ضخامت بدنه K mm	تنظیم ضخامت با تیغه‌های میانی Number of required inside blades		
6.35	0	0	0
7.94	1	0	0
8.73	0	1	0
9.53	0	0	1
10.32	1	1	0
11.11	1	0	1
11.91	0	1	1
12.70	0	0	2
13.49	1	1	1
14.29	1	0	2
15.08	0	1	2
15.88	0	0	3
16.67	1	1	2
17.46	1	0	3
18.26	0	1	3
19.05	0	0	4
19.84	1	1	3
20.64	1	0	4
21.43	0	1	4
22.23	1	1	4

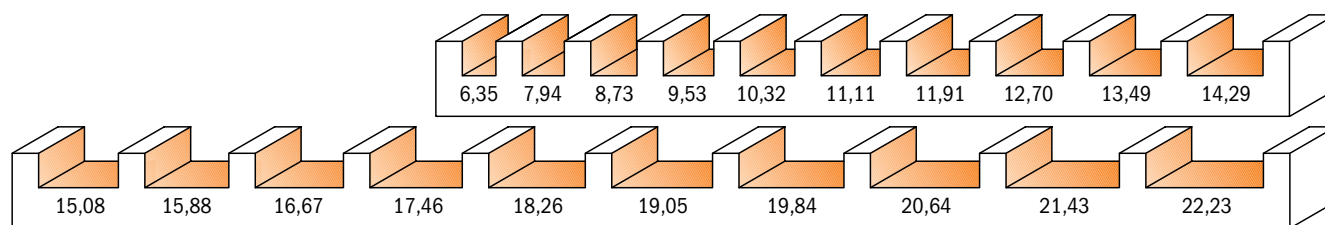

قطر D mm	شفت B mm	تعداد دندانه Z	تعداد تیغه‌های میانی ضخامت P			ضخامت الماسه K mm		زاویه الماسه $\alpha$	کد سفارش ORDER NO
			3.2 mm	2.4 mm	1.6 mm				
200	30	24	4 عدد	1 عدد	1 عدد	6,35	22,23	-5° Neg	230.524.08M

297

آره آلومینیوم بر

Non-Ferrous Metal & Laminated Panel Saw Blades Industrial Line

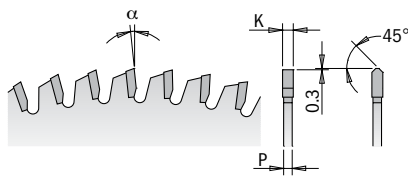

قطر	شفت	تعداد دندانه	ضخامت الماسه	ضخامت بدنه	زاویه الماسه	کد سفارش
D mm	B mm	Z	K mm	P mm	$\alpha$	ORDER NO
250	32	80	3,2	2,5	-6° Neg.	297.080.10p
300	32	96	3,2	2,5	-6° Neg.	297.096.12p
350	32	108	3,2	2,5	-6° Neg.	297.108.14p
400	32	108	3,8	3,2	-6° Neg.	297.108.16p
400	30	120	3,8	3,2	-6° Neg.	297.120.16m
450	30	140	3,8	3,2	-6° Neg.	Y297.140.18m
450	32	108	3,8	3,2	-6° Neg.	297.108.18p

284

آره آلومینیوم بر

Non-Ferrous Metal & Plastic Material Saw Blades Industrial Line

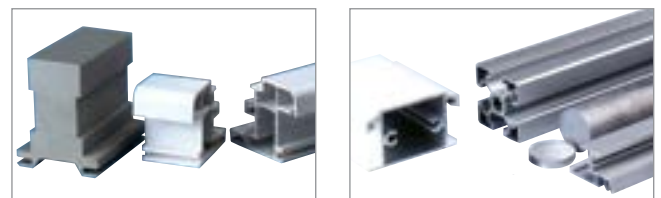
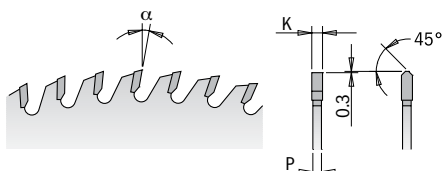

قطر	شفت	تعداد دندانه	ضخامت الماسه	ضخامت بدنه	زاویه الماسه	کد سفارش
D mm	B mm	Z	K mm	P mm	$\alpha$	ORDER NO
420	32	96	3,8	3,2	5°	284.096.17p
450	32	108	3,8	3,2	5°	284.108.18p



## 1. Saw Blades

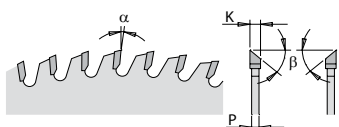

### 283

### آره تیزبر

Fine Cut-Off Saw Blades for Two-Sided Melamine Industrial Line



بدون نیاز به خطزن

قطر	شفت	تعداد دندانه	ضخامت الماسه	ضخامت بدنه	زاویه بتا	زاویه الماسه	کد سفارش
D mm	B mm	Z	K mm	P mm	$\beta$	$\alpha$	ORDER NO
250	30	80	3,2	2,2	40°	-2° Neg.	283.080.10m
300	30	96	3,2	2,2	40°	2°	283.096.12m
350	30	108	3,5	2,5	40°	5°	283.108.14m

### 233

### آره کورین بر

Solid Surface Saw Blades Industrial Line

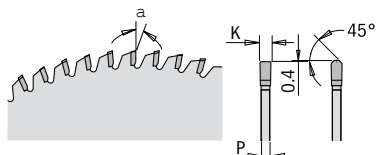

قطر	شفت	تعداد دندانه	ضخامت الماسه	ضخامت بدنه	زاویه الماسه	کد سفارش
D mm	B mm	Z	K mm	P mm	$\alpha$	ORDER NO
300	30	84	3,2	2,5	0°	223.084.12m



222

آره پلکسی گلسر

PVC & Plexiglass Saw Blades Industrial Line



قطر	شفت	تعداد دندانه	ضخامت الماسه	ضخامت بدنه	زاویه الماسه	کد سفارش
D mm	B mm	Z	K mm	P mm	$\alpha$	ORDER NO
250	30	80	2,8	2,2	-3° Neg.	222.080.10m
300	30	96	2,8	2,2	-3° Neg.	222.096.12m

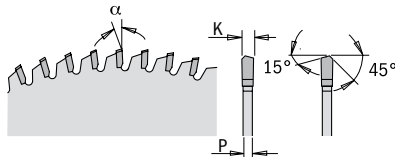

226

آره آهنر

Dry Cutter Saw Blades for Metal Industrial Line



قطر	شفت	تعداد دندانه	ضخامت الماسه	ضخامت بدنه	زاویه الماسه	کد سفارش
D mm	B mm	Z	K mm	P mm	$\alpha$	ORDER NO
305	30	80	2,2	1,8	0°	226.080.12m
355	30	90	2,2	1,8	0°	226.090.14m

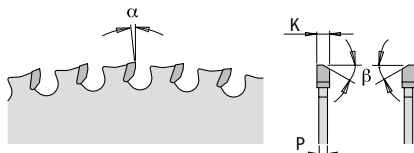

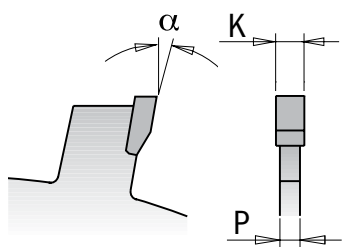

240

آره شیازرن (مناسب دستگاه فرز زمینی)

Grooving Saw Blades Industrial Line



قطر	شفت	تعداد دندانه	ضخامت الماسه	ضخامت بدنه	زاویه الماسه	کد سفارش
D mm	B mm	Z	K mm	P mm	$\alpha$	ORDER NO
150	35	12	2,0	1,4	15°	240.020.06R
150	35	12	3,0	2,0	15°	240.030.06R
180	35	18	3,0	2,0	15°	240.030.07R
150	35	12	4,0	3,0	15°	240.040.06R
180	35	18	4,0	3,0	15°	240.040.07R
150	35	12	5,0	3,0	15°	240.050.06R
180	35	18	5,0	3,0	15°	240.050.07R
150	35	12	6,0	3,0	15°	240.060.06R
180	35	18	6,0	3,0	15°	240.060.07R

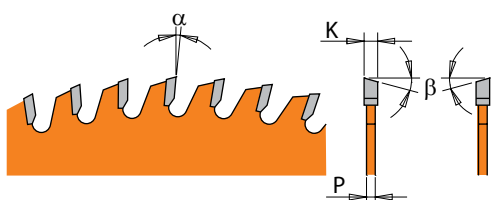
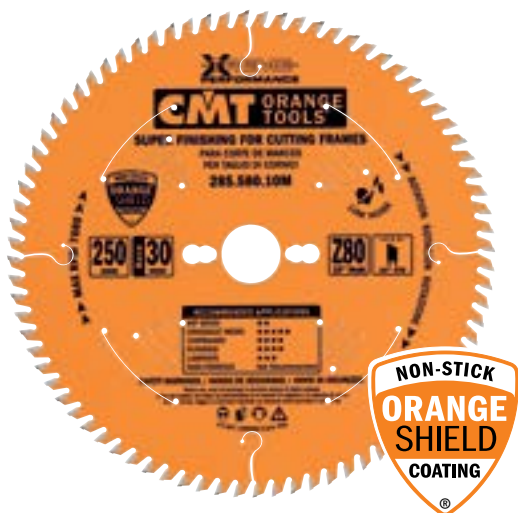

285

آره روکش سرامیک (جنرال بُر)

Super Finishing Saw Blades for Cutting Frames XTreme Line

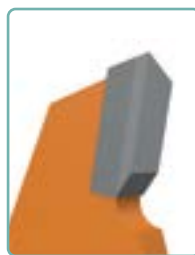

قطر	شفت	تعداد دندانه	ضخامت الماسه	ضخامت بدنه	زاویه الماسه	کد سفارش
D mm	B mm	Z	K mm	P mm	$\alpha$	ORDER NO
250	30	80	3,0	2,5	10°	285.580.10m
300	30	96	3,0	2,5	10°	285.596.12m

## تیغ اورفیرز و سی ان سی Router Bits & Set

۳۴	تیغ اتصال نیم‌گرد	۱۶	شیارزن تمام الماسه
۳۴	تیغ اتصال	۱۶	شیارزن جوشی
۳۵	تیغ اتصال افقی لبه	۱۶	شیارزن ماریچ تک تیغ
۳۶	تیغ اتصال درآوری کشو	۱۷	شیارزن انگشتی ماریچ
۳۷	تیغ ناودانی	۱۷	شیارزن آلومینیوم
۳۸	تیغ بانکی CNC	۱۸	شیارزن ماریچ تمام الماسه
۳۸	ست فاق و زبانه	۱۸	مته دم‌چلچله
۴۰-۳۹	تیغ پروفیل لبه	۱۹	پرداخت لبه صاف
۴۱	تیغ اتصال نیم‌گرد	۱۹	پرداخت ماریچ
۴۱	فرز پخ بدون بلبرینگ	۲۰	پرداخت لبه کج
۴۲	تیغ قاب پنجره	۲۰	پرداخت دایموند
۴۳	تیغ پروفیل نفوذی	۲۱	پرداخت تعویضی
۴۳	تیغ پروفیل ناودانی	۲۱	پرداخت تعویضی دو بلبرینگ
۴۴	تیغ نیم‌گرد	۲۲	پرداخت لبه کج دو بلبرینگ
۴۴	تیغ دستگیره دراور	۲۲	پرداخت بلبرینگ وسط
۴۵	تیغ پروفیل لبه	۲۳	فرز نگارش ۱ فرز حکاکی
۴۵	تیغ اتصال فاق و زبانه	۲۴-۲۳	فرز حکاکی
۴۶	تیغ قرنیز	۲۴	تیغ فاق و زبانه
۴۶	تیغ فاق و زبانه کابینتی	۲۴	تیغ مدرج CNC
۴۷	تیغ حاشیه	۲۵	فرز حکاکی قابل تعویض
۴۷	مته جاکلید	۲۵	کف تراش تیغ تعویضی
۴۸	دوراهه همراه ست بلبرینگ	۲۶	کیت تیغ CNC
۴۸	تیغ اتصال انگشتی	۲۷	کیت ابزار درب CNC
۴۹	تیغ لبه میز	۲۸	فرز پخ
۴۹	شیارزن خزینه‌ای	۲۹	شیارزن افقی
۵۰	مته جاشیشه	۳۰	شیارزن افقی بلبرینگ زیر
۵۰	شیارزن انگشتی	۳۰	شیارزن افقی چندتکه
۵۱	تیغ پرداخت کورین	۳۱	تیغ بانکی
۵۱	فرز کورین مدل سه پله	۳۱	شیارزن افقی لبه‌گرد
۵۲	تیغ اتصال کورین	۳۲	تیغ قاشقی
۵۲	تیغ دوراهه کورین	۳۲	تیغ رگال
۵۳	پک دو راهه	۳۳	تیغ نیم‌گرد لبه
۵۳	تیغ دو راهه	۳۳	تیغ قاشقی دوپله
		۳۳	شیارزن افقی لبه‌گرد



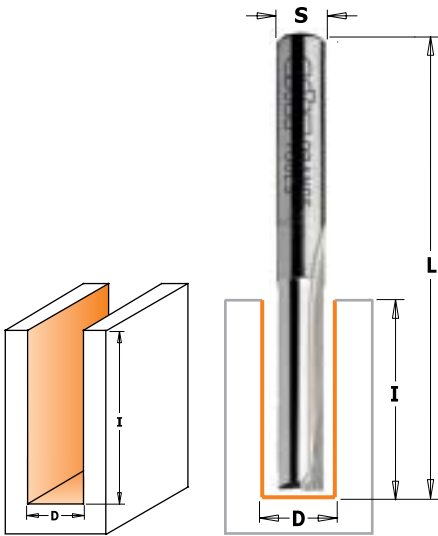

## 7/912

شیارزن تمام الماسه

Straight Bits, Long Series



قطر	کارگیر	طول	کد سفارش (شفت=S)	
D mm	I mm	L mm	ORDER NO S=Ø6mm	ORDER NO S=Ø8mm
3	11	60	712.030.11	
4	12	60	712.040.11	
5	18	60	712.050.11	
6	25,4	60	712.060.11	
8	31,7	60		912.080.11

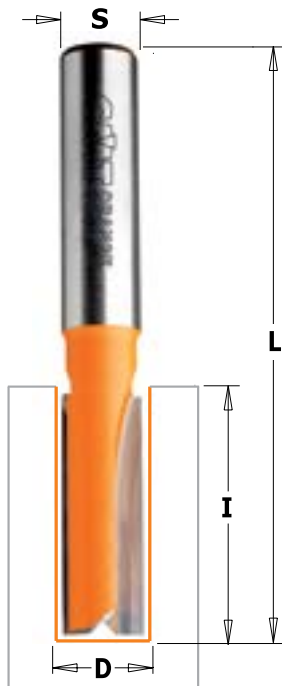

## 711/911/912

شیارزن جوشی

Straight Bits, Long Series



قطر	کارگیر	طول	کد سفارش (شفت=S)		
D mm	I mm	L mm	ORDER NO S=Ø6mm	ORDER NO S=Ø8mm	ORDER NO S=Ø12mm
6	19	60	711.060.13	911.060.13	
10	31,7	60		912.100.11	
12	31,7	60		912.120.11	
12	38,1	95			912.621.11
12	50,8	108			912.622.11
14	31,7	60		912.140.11	
14	31,7	70			912.640.11
16	31,7	66		912.160.11	
16	31,7	70			912.660.11
20	38,1	80			912.701.11

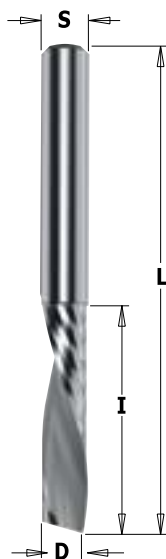

## 198

شیارزن ماریچ تک تیغ

Solid Carbide Downcut Spiral Bits



قطر	کارگیر	طول	شفت	کد سفارش (راست گرد)
D mm	I mm	L mm	S mm	ORDER NO Right-hand
6	27	60	6	198.660.11



199

شیارزن انگشتی مارپیچ

Round Nose Solid Carbide Upcut Spiral Bits

**HWM Z2 RH**

قطر D mm	کارگیر l mm	طول L mm	شعاع انحنای R mm	کد سفارش (شفت=S)		
				ORDER NO S=Ø6mm	ORDER NO S=Ø8mm	ORDER NO S=Ø12mm
6	27	70	3	199.060.11		
8	32	80	4		199.081.11	
12	35	80	6			199.120.11



189

شیارزن آلومینیوم

5% Co HS Spiral Bits for Aluminium Positive Single Flute for High Cutting Depth

**HSS Z1 RH**

قطر D mm	کارگیر l mm	کارگیر اولیه l1 mm	طول L mm	کد سفارش (شفت=S)
				ORDER NO S=Ø8mm
5	35	18	80	189.050.51
10	95	14	120	189.100.51

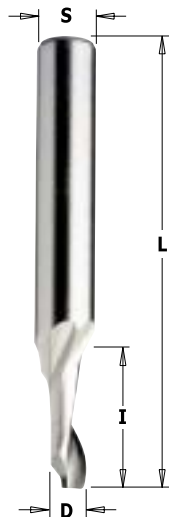

188

شیارزن آلومینیوم

5% Co HS Spiral Bits for Aluminium Positive Single Flute

**HSS Z1 RH**

قطر D mm	کارگیر l mm	طول L mm	کد سفارش (شفت=S)
			ORDER NO S=Ø8mm
6	40	100	188.061.51
5	40	100	188.051.51

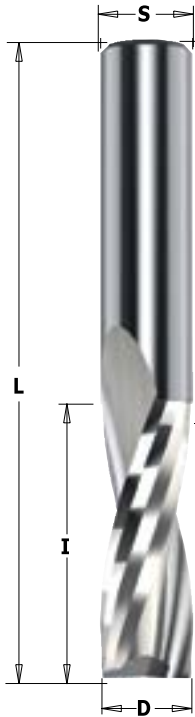

191

شیارزن ماریچج تمام الماسه

Solid Carbide Upcut Spiral Bits



قطر	کارگیر	طول	کد سفارش (شفت=S)		
D mm	I mm	L mm	ORDER NO S=Ø6mm	ORDER NO S=Ø8mm	ORDER NO S=Ø12mm
3	12	60	191.630.11		
4	15	60	191.640.11		
5	17	60	191.650.11		
6	27	70	191.060.11		
8	32	80		191.081.11	
8	42	90		191.082.11	
10	32	80		191.800.11	
10	42	90			191.901.11
12	35	83			191.120.11
12	52	100			191.122.11



7/918

مته دمچلچله

Dovetail Bits



قطر	کارگیر	طول	زاویه برش	کد سفارش (شفت=S)	
D mm	I mm	L mm	A mm	ORDER NO S=Ø6mm	ORDER NO S=Ø8mm
9,5	9,5	52,5	9°	718.095.11	918.095.11
12,7	12,7	52,4	14°	718.127.11	918.127.11
12,7	20,6	69,8	8°		918.129.11



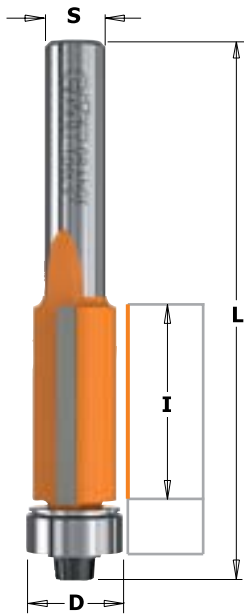

Z3 8/906.227.11

7/906

پرداخت لبه صاف

Flush Trim Bits

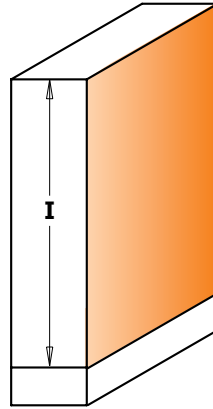

قطر D mm	کارگیر I mm	طول L mm	کد سفارش (S=شفت)			متعلقات			
			ORDER NO S=Ø6mm	ORDER NO S=Ø8mm	ORDER NO S=Ø12mm				
6,35	25,4	63,5	706.064.11			791.035.00		990.060.00	541.008.00
9,5	25,4	68,2	706.095.11			791.002.00	990.422.00	990.058.00	
9,5	25,4	68,2		906.095.11		791.002.00	990.422.00	990.058.00	
12,7	25,4	71		906.227.11		791.003.00	990.423.00	990.058.00	
12,7	38,1	94			906.629.11	791.003.00	990.423.00	990.058.00	
12,7	50,8	104			906.630.11	791.003.00	990.423.00	990.058.00	
12,7	12,7	57,8		906.128.11		791.003.00	990.423.00	990.058.00	
19	16	57,1		906.190.11					

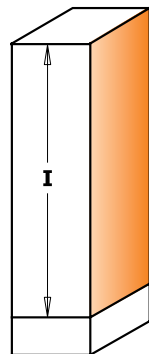
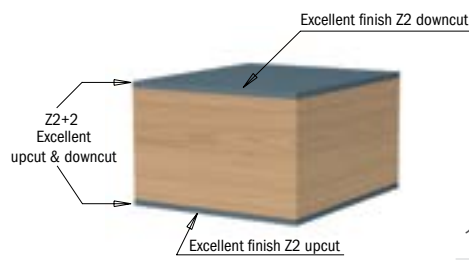
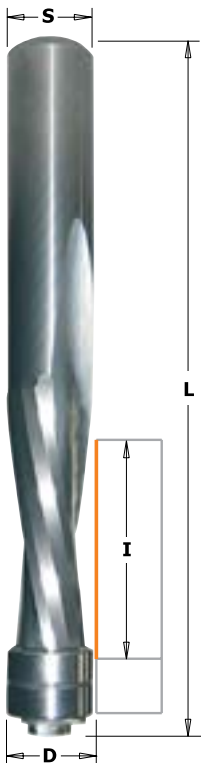

190B-191B

پرداخت ماریج

Double-Bearing Spiral Flush Trim Bits

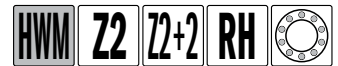

قطر D mm	کارگیر I mm	طول L mm	کد سفارش (S=شفت)		متعلقات	
			ORDER NO S=Ø6.35mm	ORDER NO S=Ø12mm		
پایین برش و بالا برش						
12,7	42	114		190.127.11B	791.010.00	541.301.00
پایین برش بالا برش						
6,35	25,4	76,2	191.008.11B		791.035.00	541.350.00
12,7	50,8	114		191.127.11B	791.010.00	541.301.00

## 2. Router Bits & Set

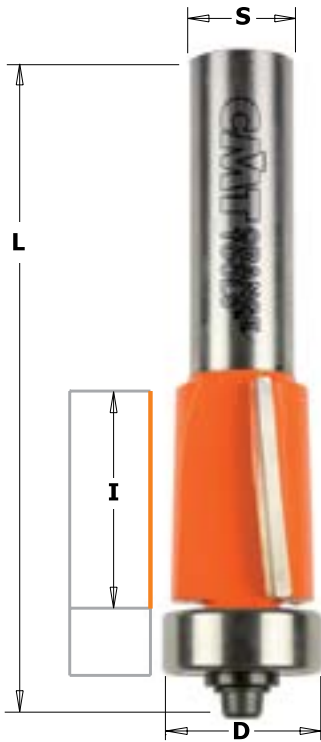

906

پرداخت لبه کج

Super-Duty Flush Trim Bits

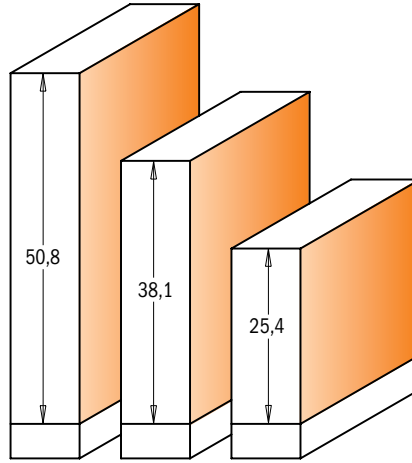

قطر	کارگیر	طول	زاویه الماسه	کد سفارش (شفت=S)		متعلقات		
D mm	I mm	L mm	$\alpha$	ORDER NO S=Ø8mm	ORDER NO S=Ø12mm			
19	25,4	73,9	-5°	906.191.11		791.004.00	541.550.00	990.058.00
19	25,4	86,5	-5°		906.691.11	791.004.00	541.550.00	990.058.00
19	38,1	92,9	-3°		906.692.11	791.004.00	541.550.00	990.058.00
19	50,8	109,5	-3°		906.690.11	791.004.00	541.550.00	990.058.00

906

پرداخت دایموند

DP Flush Trim Bits for Laminates



XTREME

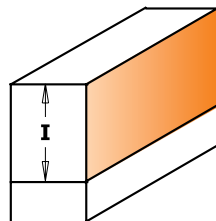
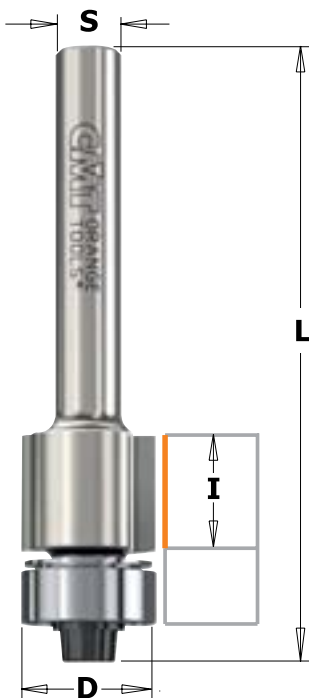

کارگیر قطر		طول	کد سفارش (شفت=S)	متعلقات			
D mm	I mm	L mm	ORDER NO S=Ø8mm				
12,7	11	58,1	906.128.61	990.423.00	791.003.00	990.058.00	991.057.00



## 657

### پرداخت تعویضی

Flush Trim Bits with Insert Knives

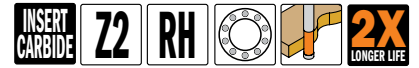

طول			کد سفارش (شفت=S)		متعلقات			
قطر	کارگیر	طول	ORDER NO S=Ø8mm	ORDER NO S=Ø12mm				
D mm	I mm	L mm						
19	30	85	657.191.11		790.300.00	990.075.00	991.061.00	791.007.00
19	50	112		657.991.11	790.500.00	990.075.00	991.061.00	791.007.00

## 657B

### پرداخت تعویضی دو بلبرینگ

Pattern/Flush Trim Bits with Insert Knives

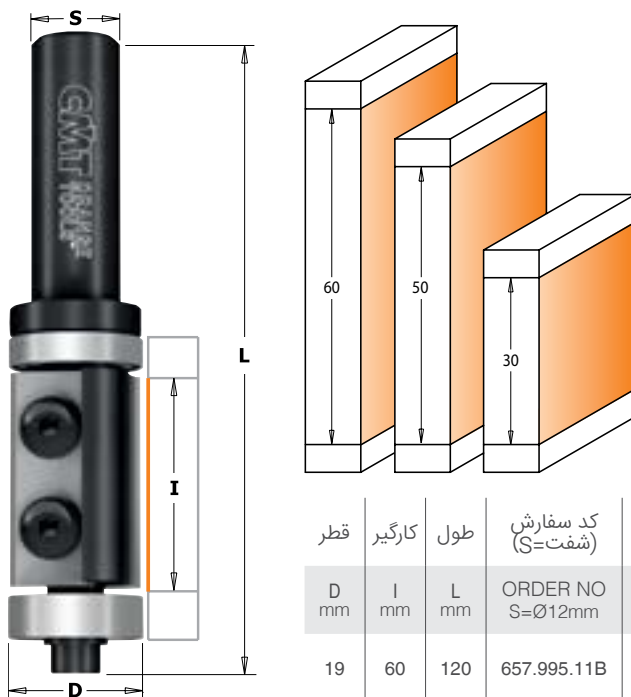

طول			کد سفارش (شفت=S)		متعلقات					
قطر	کارگیر	طول	ORDER NO S=Ø12mm							
D mm	I mm	L mm								
19	60	120	657.995.11B	790.600.00	990.075.00	791.007.00	990.052.00	791.011.00	541.002.00	

## 906B

پرداخت لبه کج دو بلبرینگ  
Flush Trim Router Bits with Double Bearing

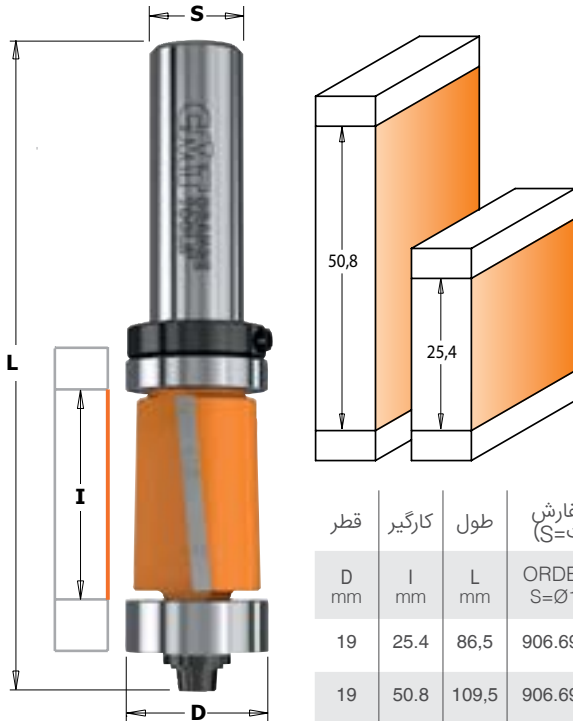

قطر	کارگیر	طول	کد سفارش (S=شفت)	متعلقات					
D mm	I mm	L mm	ORDER NO S=Ø12mm						
19	25,4	86,5	906.691.11B	791.004.00	541.550.00	990.058.00	991.057.00	791.011.00	541.005.00
19	50,8	109,5	906.690.11B						

## 7/911B - 912B

پرداخت بلبرینگ وسط  
Pattern Bits

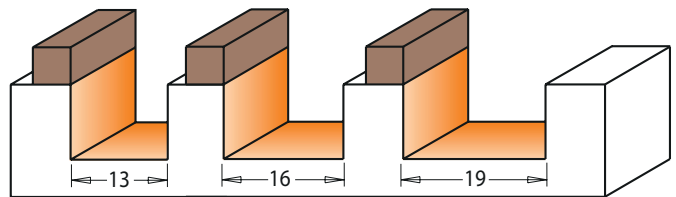

قطر	کارگیر	طول	کد سفارش (شفت S=)			متعلقات		
			ORDER NO S=Ø6mm	ORDER NO S=Ø8mm	ORDER NO S=Ø12mm			
13	20	57	711.130.11B			791.023.00	541.003.00	991.056.00
16	20	57		911.160.11B		791.025.00	541.004.00	991.056.00
16	31,7	66,5		912.160.11B		791.025.00	541.004.00	991.056.00
19	38,1	82,5			912.690.11B	791.011.00	541.005.00	991.056.00
19	50,8	92			912.691.11B	791.011.00	541.005.00	991.056.00

958

فرز نگارش | فرز حکاکی

Laser Point Bit



8/958.001



8/958.003

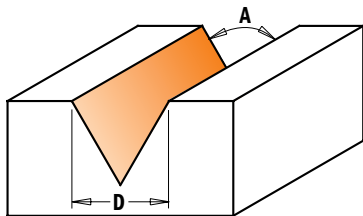

قطر	کارگیر	طول	زاویه برش	تعداد تیغه	کد سفارش (S=شفت)
D mm	I mm	L mm	A mm	Z	ORDER NO S=Ø8mm
12,7	11	57,2	60°	3	958.001.11
12,7	10	50,8	60°	2	958.003.11

7/915

فرز حکاکی (V)

V-Grooving Bits (90°)

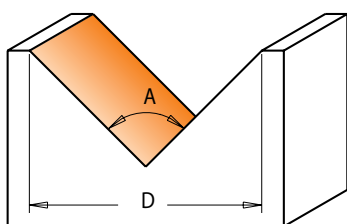

قطر	کارگیر	طول	زاویه برش	کد سفارش (S=شفت)		
D mm	I mm	L mm	A mm	ORDER NO S=Ø6mm	ORDER NO S=Ø8mm	ORDER NO S=Ø12mm
6	8	38,1	90°	715.060.11		
9,5	12,7	44,5	90°		915.095.11	
12,7	12,7	44,5	90°		915.127.11	
16	12,7	52,8	90°		915.160.11	
16	12,7	63,5	90°			915.660.11
19	16	63,5	90°			915.690.11
31,7	19	63,5	90°			915.817.11



915

فرز حکاکی (V)

Laser Point Bit



قطر	کارگیر	طول	زاویه برش	کد سفارش (S=شفت)
D mm	I mm	L mm	A mm	ORDER NO S=Ø12mm
60	12	70	140°	S915.04322

955

تیغ فاق و زبانه

2-Piece Entry Door Router Bit Set

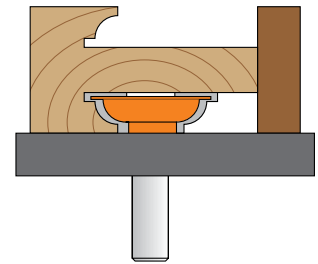
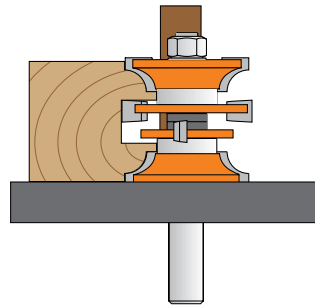
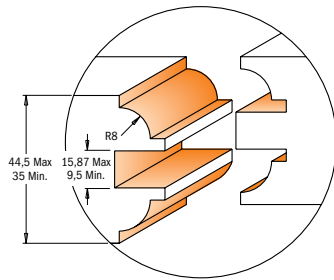

قطر	کارگیر	کد سفارش (S=شفت)	متعلقات							
D mm	I mm	ORDER NO S=Ø12mm	8-22mm	up	down		0,1mm	0,3mm	3mm	
44,5-48	35-44,5	955.806.11	791.005.00	822.021.11A	822.021.11B	822.022.11	541.515.00	541.516.00	541.500.00	990.020.00

663

تیغ مدرج CNC

Adjustable Chamfering CNC Cutter

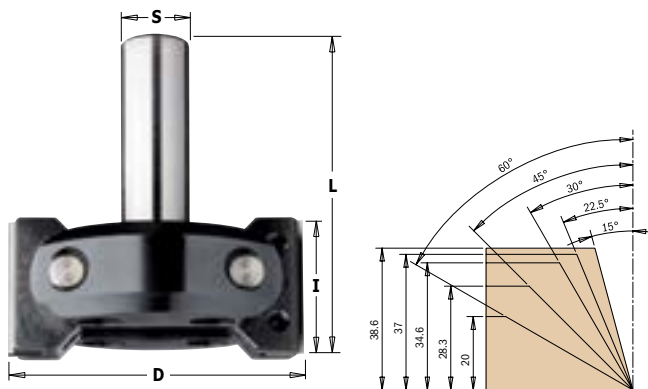

قطر	کارگیر	زاویه برش	طول	شفت	کد سفارش راست گرد
D mm	I mm	A	L mm	S mm	ORDER N Right-hand rotation
85	39.5	0°-45° - 0°+90°	92	20	663.201.11

### 663

### فرز حکاکی قابل تعویض

V-Groove - Folding - Signmaking CNC Router Cutters with Insert Knives

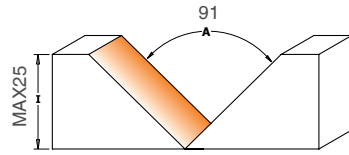
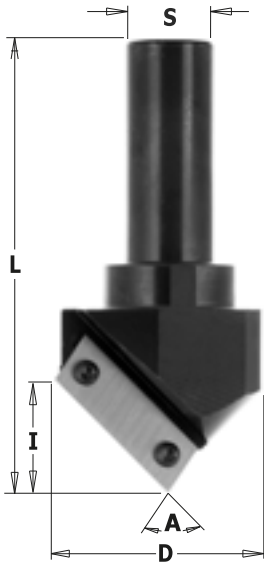

شفت (S)	قطر (D)	کارگیر (I)	طول (L)	زاویه برش (A)	کد سفارش (S=شفت)
S mm	D mm	I mm	L mm	A mm	ORDER NO S=Ø20mm
20	52	25	100	91°	663.101.11

### 665

### فرز حکاکی قابل تعویض

V-Grooving & Signmaking Router Bits with indexable knives (90°)

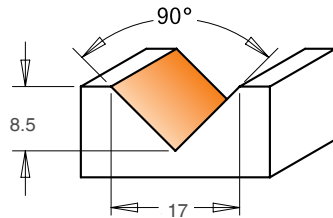

قطر (D)	کارگیر (I)	طول (L)	زاویه برش (A)	کد سفارش (S=شفت)	متعلقات
D mm	I mm	L mm	A mm	ORDER NO S=Ø8mm	
17	8,5	53	90°	665.170.11	

### 663

### کف تراش تیغ تعویضی

Spoilboard Surfacing Router Cutters with Insert Knives

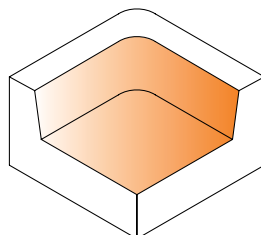

قطر (D)	کارگیر (I)	طول (L)	شفت (S)	کد سفارش راست‌گرد	متعلقات
D mm	I mm	L mm	S mm	ORDER NO. Right-hand rotation	
60	12	80	12x50	663.004.11	790.120.03 990.075.00
80	12	90	20x60	663.003.11	790.120.03 990.075.00

616

کیت تیغ CNC

Complete Set for Decorating on MDF



شفٹ	کد سفارش	متعلقات		
S mm	ORDER NO			
20	616.000.01	616.200	990.077.00	991.061.00

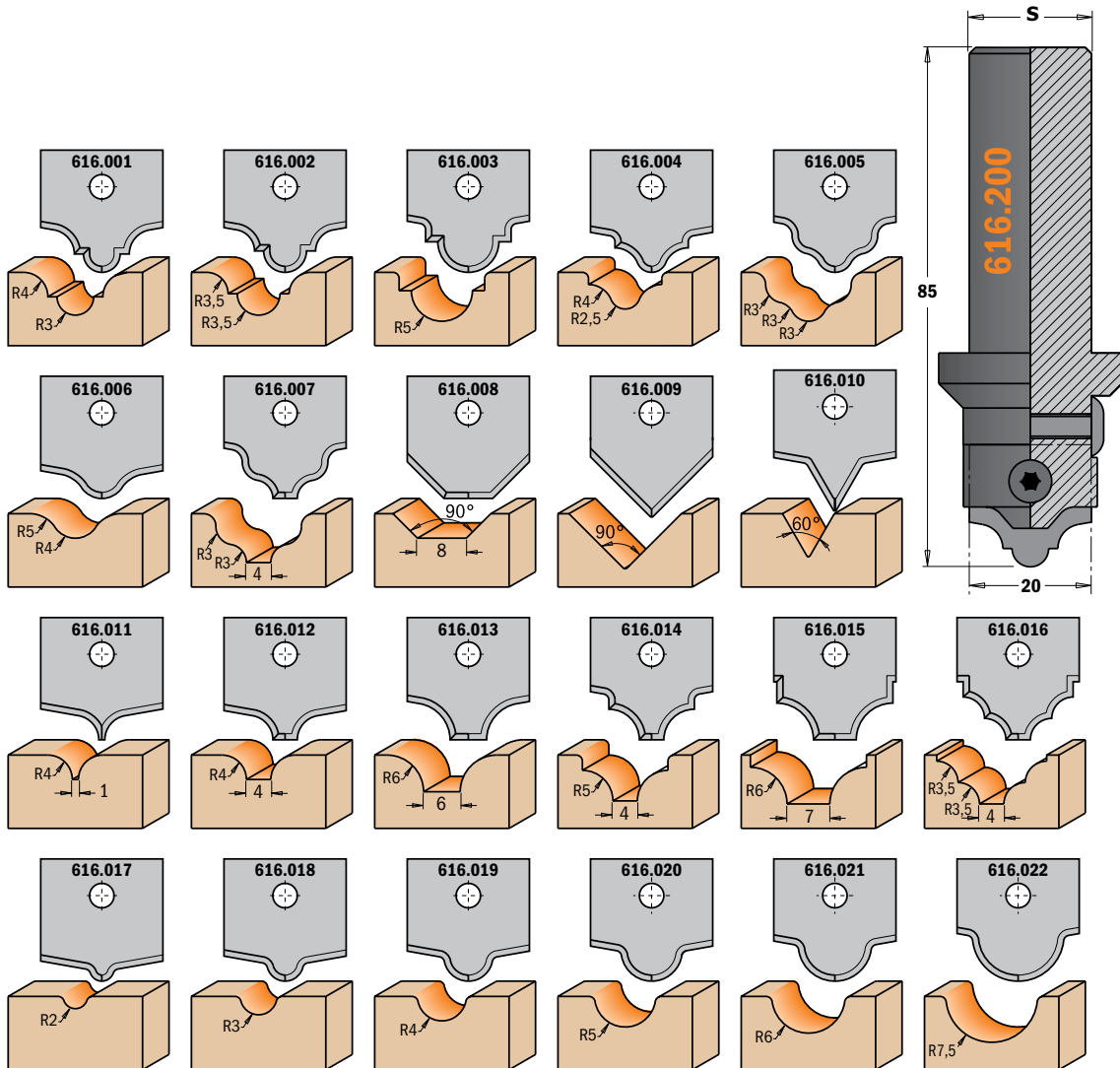

# 615

## CNC کیت ابزار درب

Complete Set for MDF Doors



مشخصات	کد سفارش
Description	ORDER NO S=Ø20mm
کیت کامل ابزار درب	615.004.01

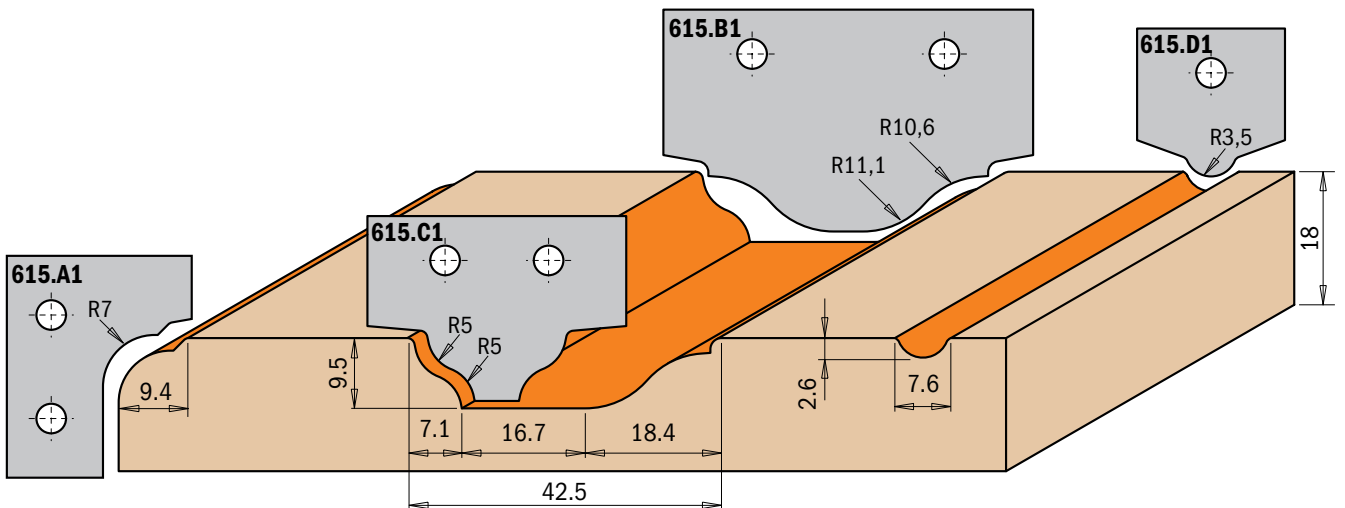
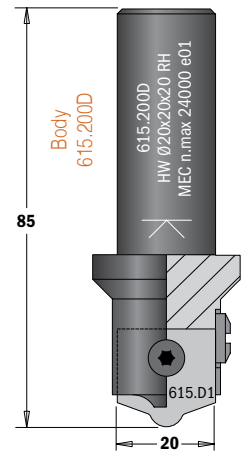
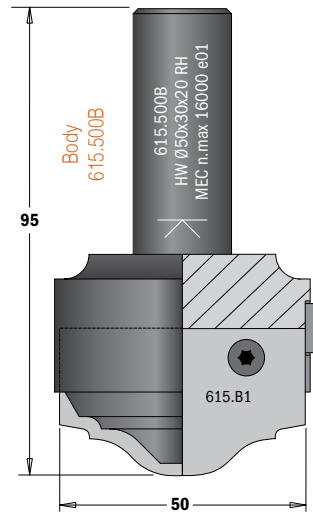
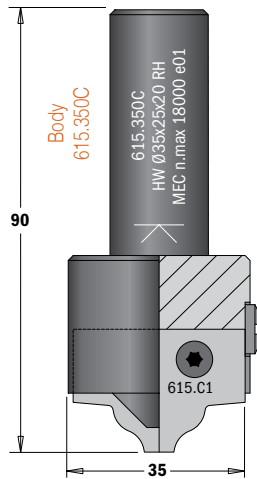
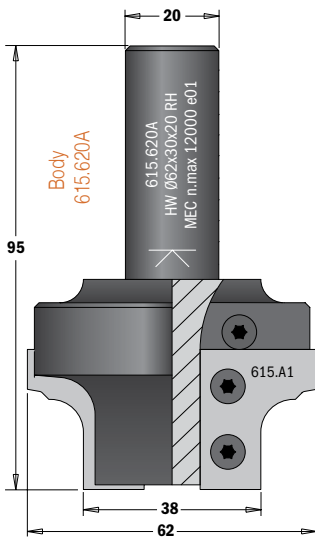

710-936-957

فرز پخ

Chamfer Bits

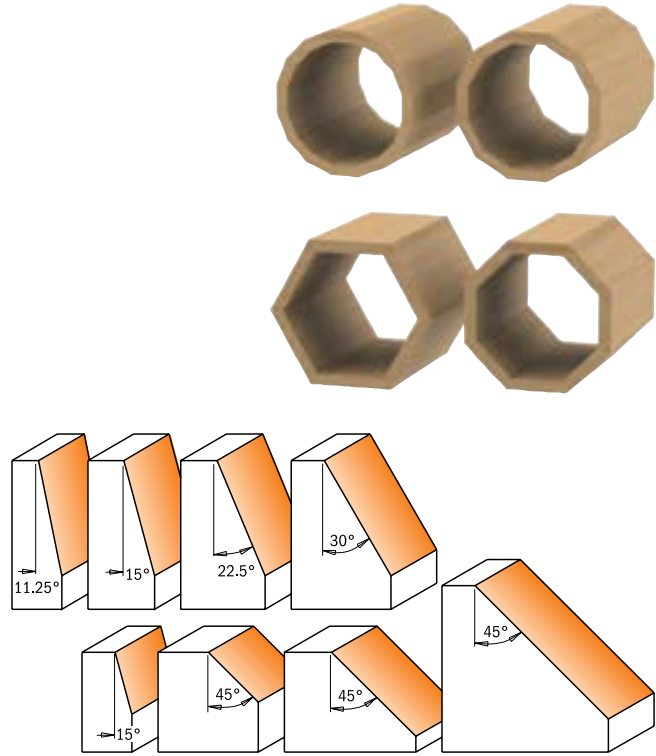
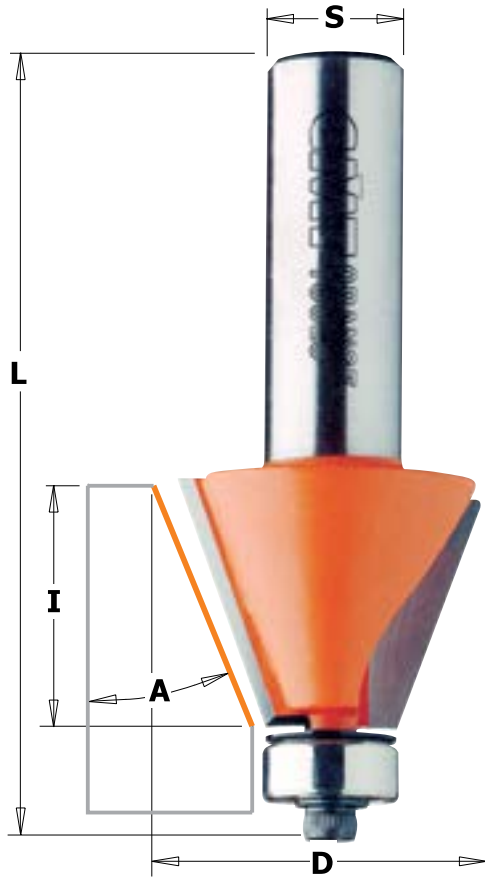

قطر D mm	کارگیر I mm	طول L mm	زاویه برش A mm	کد سفارش (شفت=S)			متعلقات			
				ORDER NO S=Ø6mm	ORDER NO S=Ø8mm	ORDER NO S=Ø12mm				
22,2	10	54,9	25°		936.190.11		990.423.00	791.003.00	990.058.00	991.057.00
27	5,5	51,5	45°	710.260.11			990.423.00	791.003.00	990.058.00	991.057.00
31,7	9,5	53	45°		936.280.11		990.423.00	791.003.00	990.058.00	991.057.00
45	18	60,2	45°		936.420.11		990.423.00	791.003.00	990.058.00	991.057.00
45	18	66,5	45°			936.920.11	990.423.00	791.003.00	990.058.00	991.057.00
65	26	76,7	45°			936.950.11	990.423.00	791.003.00	990.058.00	991.057.00
19	11,5	54,9	15°		936.130.11		990.423.00	791.003.00	990.058.00	991.057.00
38,5	22	71,1	30°			957.501.11	990.423.00	791.003.00	990.058.00	991.057.00
31	22	71,1	22,5°			957.502.11	990.423.00	791.003.00	990.058.00	991.057.00
24,5	22	71,1	15°			957.503.11	990.423.00	791.003.00	990.058.00	991.057.00
21,5	22	71,1	11.25°			957.504.11	990.423.00	791.003.00	990.058.00	991.057.00



## 7/922

### شیارزن افقی

#### Slot Cutters

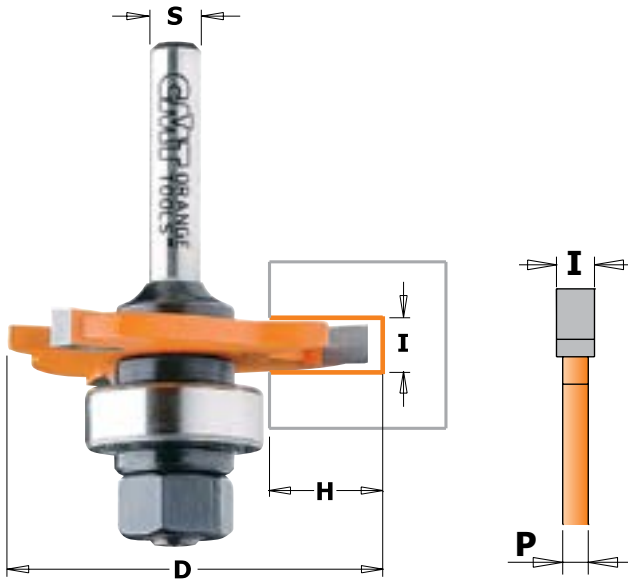
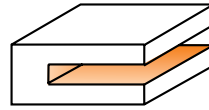

قطر	کارگیر	ضخامت بدنه	عمق نفوذ	کد سفارش (S=شفت)	
D mm	I mm	P mm	H mm	ORDER NO S=Ø6mm	ORDER NO S=Ø8mm
47,6	1,5	1,07	12,8	722.315.11A	922.315.11A
47,6	2	1,27	12,8	722.320.11A	922.320.11A
47,6	2,5	1,27	12,8	722.325.11A	922.325.11A
47,6	3	1,27	12,8	722.330.11A	922.330.11A
47,6	3,5	2,07	12,8	722.335.11A	922.335.11A
47,6	4	2,07	12,8	722.340.11A	922.340.11A
47,6	5	2,86	12,8	722.350.11A	922.350.11A
47,6	6	4,45	12,8	722.360.11A	922.360.11A

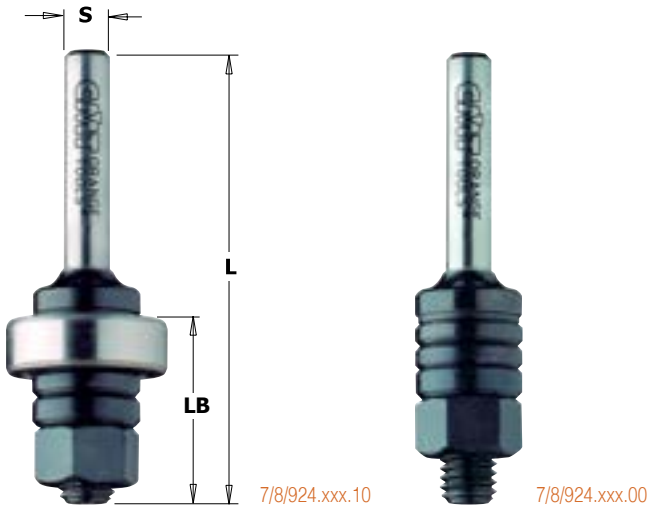

قطر	ضخامت بدنه	طول میانی	کد سفارش (S=شفت)
D mm	L mm	LB mm	ORDER NO S=Ø12mm
M8	71	29,75	924.131.00
-	67,5	26	924.120.10

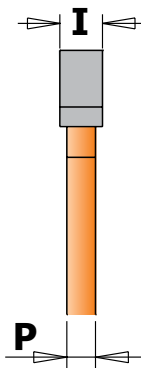
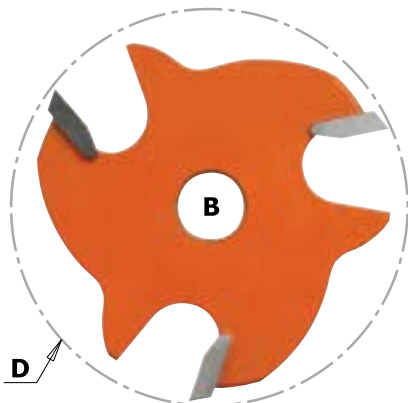

قطر	کارگیر	ضخامت بدنه	شفت	کد سفارش (S=شفت)
D mm	I mm	P mm	B mm	ORDER NO S=Ø12mm
47,6	2	1,27	8	822.320.11
47,6	4	2,07	8	822.340.11
47,6	5	2,86	8	822.350.11
47,6	6	4,45	8	822.360.11
47,6	6,4	4,45	8	822.364.11

923

شیارزن افقی بلبرینگ زیر

Slot Cutters

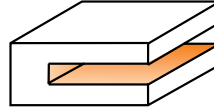
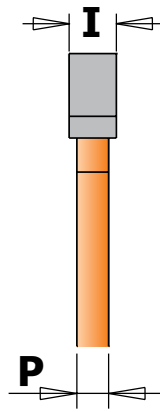
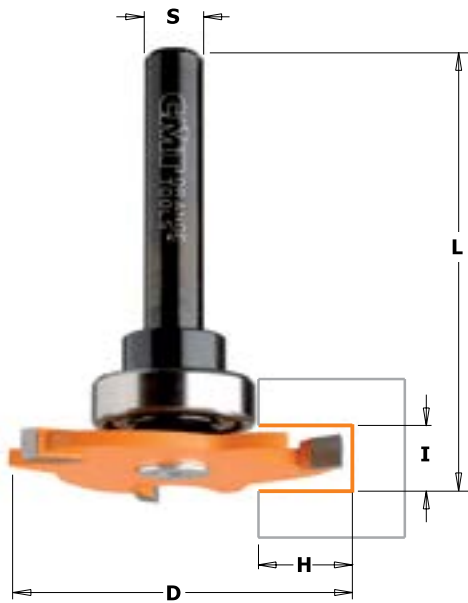

قطر	کارگیر	طول	عمق نفوذ	ضخامت بدنه	کد سفارش (S=شفت)
D mm	I mm	L mm	H mm	P mm	ORDER NO S=Ø8mm
47,6	3	58	12,8	1,27	923.330.11A
47,6	4	58,3	12,8	2,07	923.340.11A
47,6	5	63	12,8	2,86	923.350.11A

900

شیارزن افقی چندتکه

Three Wing Slot Cutter Set

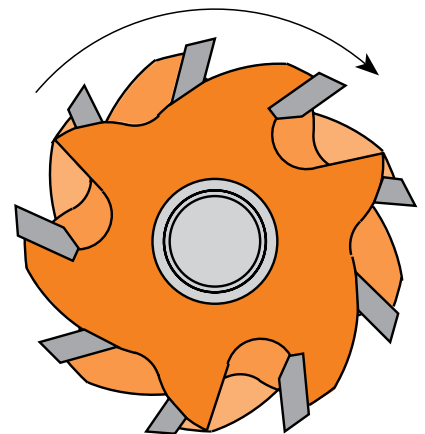
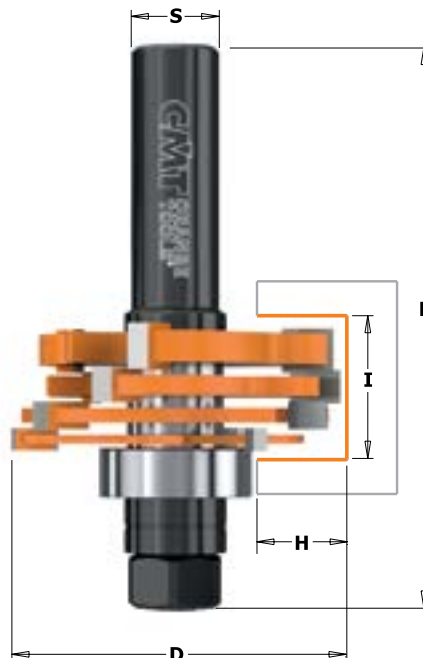
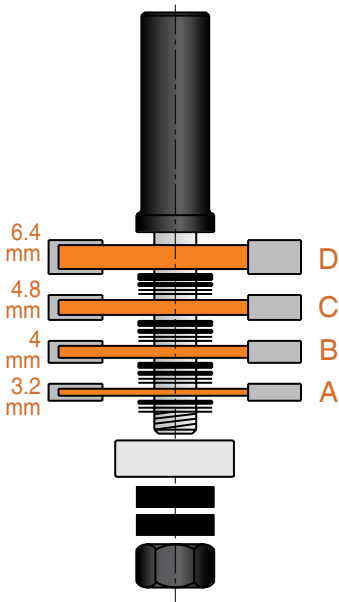

قطر	کارگیر	ضخامت بدنه	عمق نفوذ	کد سفارش (S=شفت)	متعلقات
D mm	I mm	L mm	H mm	ORDER NO S=Ø12mm	
47,6	3,2-18	81	12,8	900.506.11	 924.128.00  791.005.00  990.020.00

## 7/938

### تیغ بانکی

#### Roundover Bits

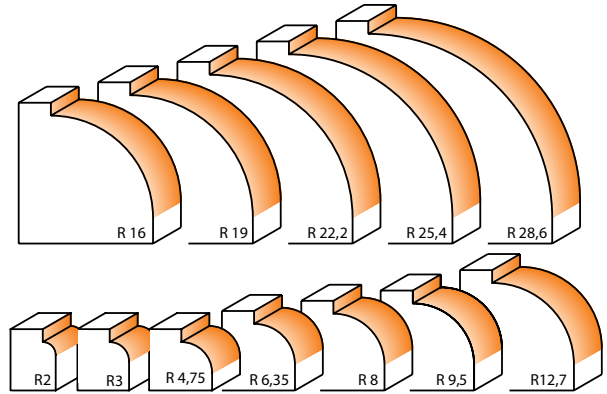

قطر D mm	کارگیر l mm	شعاع انحنا R mm	کد سفارش (شفت=S)			متعلقات			
			ORDER NO S=Ø6mm	ORDER NO S=Ø8mm	ORDER NO S=Ø12mm				
16,7	12,7	2	738.167.11			990.422.00	791.044.00	990.058.00	911.057.00
18,7	12,7	3	738.187.11			990.422.00	791.044.00	990.058.00	911.057.00
22,2	12,7	4,75	738.222.11			990.423.00	791.003.00	990.058.00	991.057.00
25,4	12,7	6,35	738.254.11			990.423.00	791.003.00	990.058.00	991.057.00
28,6	12,7	8	738.285.11			990.423.00	791.003.00	990.058.00	991.057.00
31,7	16	9,5		938.317.11		990.423.00	791.003.00	990.058.00	991.057.00
38,1	19	12,7		938.380.11		990.423.00	791.003.00	990.058.00	991.057.00
44,5	22	16		938.445.11		990.423.00	791.003.00	990.058.00	991.057.00
50,8	25,4	19			938.990.11	990.423.00	791.003.00	990.058.00	991.057.00
57,1	28,5	22,2			938.991.11	990.423.00	791.003.00	990.058.00	991.057.00
63,5	33,3	25,4			938.992.11	990.423.00	791.003.00	990.058.00	991.057.00
76,2	38,1	28,6			938.993.11	541.550.00	791.004.00	990.058.00	991.057.00
82,5	44,4	31,75			938.994.11	541.550.00	791.004.00	990.058.00	991.057.00
88,9	44,4	38,1			938.996.11	990.423.00	791.003.00	990.058.00	991.057.00

## 822B

### شیارزن افقی لبه‌گرد

#### Flooring Router Bits

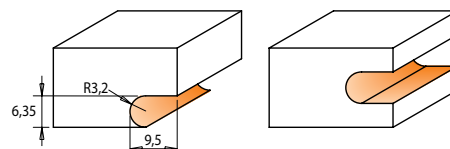

قطر D mm	کارگیر l mm	طول L mm	عمق نفوذ H mm	شعاع انحنا R mm	کد سفارش (شفت=S)	متعلقات			
						ORDER NO S=Ø6.35mm			
31,75	6,35	47,6	9,5	3,2	822.024.11B	791.010.00	541.001.00	990.005.00	991.056.00

## 2. Router Bits & Set

### 7/937

تیغ قاشقی

Cove Bits

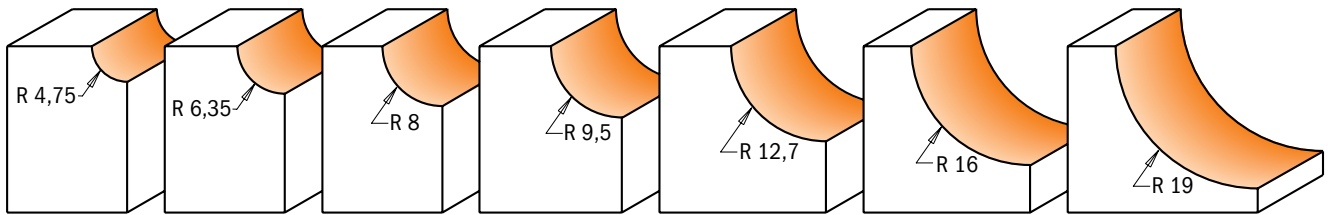
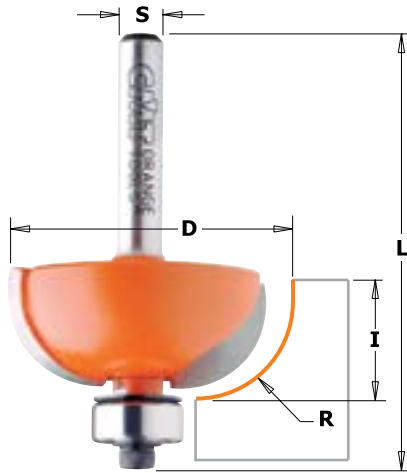

قطر D mm	کارگیر I mm	ضخامت بدنه L mm	شعاع انحنای R mm	کد سفارش (شفت S=)			متعلقات			
				ORDER NO S=Ø6mm	ORDER NO S=Ø8mm	ORDER NO S=Ø12mm				
22,2	12,7	54,9	4,75		937.190.11		990.423.00	791.003.00	990.058.00	991.057.00
25,4	12,7	54,9	6,35		937.222.11		990.423.00	791.003.00	990.058.00	991.057.00
28,7	12,7	54,2	8		937.254.11		990.423.00	791.003.00	990.058.00	991.057.00
31,7	12,7	54,2	9,5	737.286.11	937.286.11		990.423.00	791.003.00	990.058.00	991.057.00
38,1	15,5	64	12,7			937.850.11	990.423.00	791.003.00	990.058.00	991.057.00
38,1	15,5	57,7	12,7	737.350.11	937.350.11		990.423.00	791.003.00	990.058.00	991.057.00
44,5	18,5	67	16			937.950.11	990.423.00	791.003.00	990.058.00	991.057.00
50,8	22,2	70,7	19			937.951.11	990.423.00	791.003.00	990.058.00	991.057.00
50,8	12,7	61,2	14,3-35			937.955.11	990.423.00	791.003.00	990.058.00	991.057.00

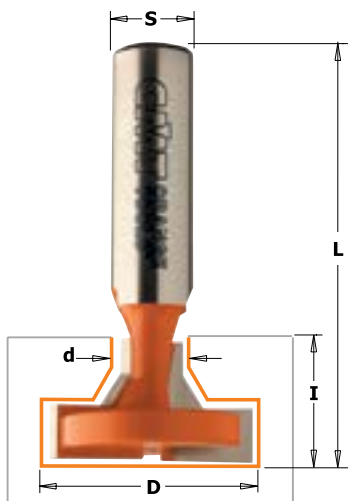

### 950

تیغ رگال

T-Slot Bits

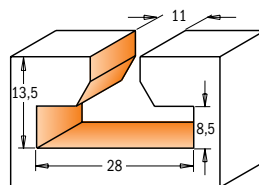

قطر D mm	قطر کوچک d mm	کارگیر I mm	طول L mm	تعداد تیغه Z	کد سفارش (شفت S=)
28	11	13,5	56,3	2	ORDER NO S=Ø12mm 950.603.11

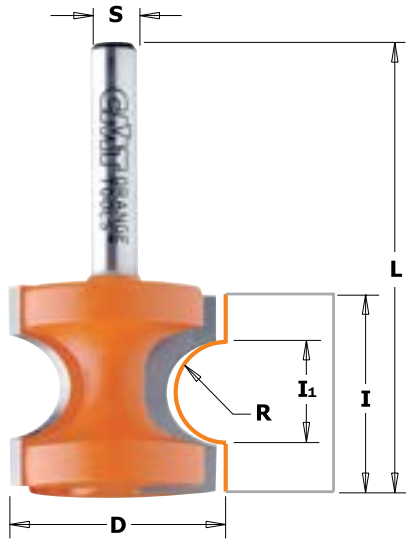

### 7/954

تیغ نیم‌گرد لبه

Bead & Bull Nose Bits

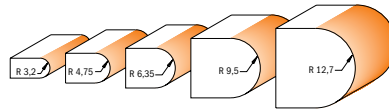

قطر D mm	کارگیر اولیه I mm	کارگیر I mm	طول L mm	شعاع انحنای R mm	کد سفارش (شفت=S)		
					ORDER NO S=Ø6mm	ORDER NO S=Ø8mm	ORDER NO S=Ø12mm
22,2	6,56	19	50,8	3,2	754.002.11		
25,4	9,85	22	54	4,75		954.003.11	
28,6	13,15	25,5	57,2	6,35		954.004.11	
34,9	19,71	35	73	9,5			954.507.11
44,5	26,3	41	79,4	12,7			954.509.11

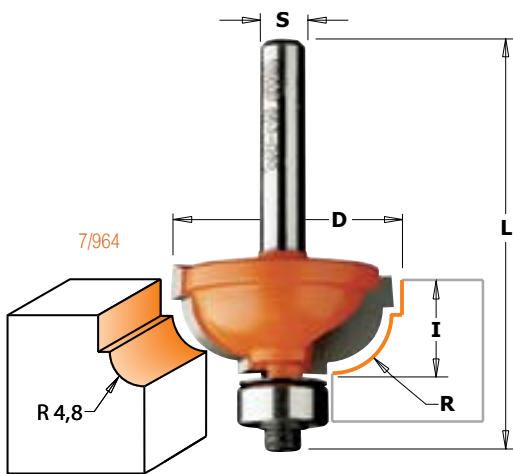

### 7/964

تیغ قاشقی دوپله

Cavetto Edge Mould Bits



قطر D mm	کارگیر I mm	طول L mm	شعاع انحنای R mm	کد سفارش (شفت=S)			متعلقات			
				ORDER NO S=Ø6mm	ORDER NO S=Ø8mm	ORDER NO S=Ø12mm				
25,4	11,5	52,8	4,8	764.048.11			990.422.00	791.002.00	990.058.00	991.057.00
31,7	14,3	55,1	8	764.080.11	964.080.11		990.422.00	791.002.00	990.058.00	991.057.00
31,7	14,3	61	8			964.580.11	990.422.00	791.002.00	990.058.00	991.057.00
25,4	11,5	52,8	4,8		964.048.11		990.422.00	791.002.00	990.058.00	991.057.00

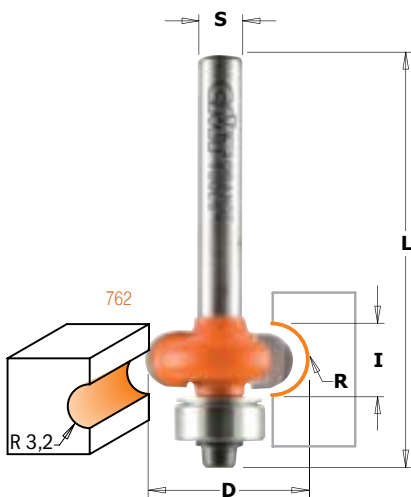

### 7/862

شیارزن افقی لبه گرد

Edge-Fluting Bits



قطر D mm	کارگیر I mm	طول L mm	شعاع انحنای R mm	کد سفارش (شفت=S)	متعلقات			
					ORDER NO S=Ø6mm			
22,7	10	57	5	762.050.11	990.423.00	791.003.00	990.058.00	991.057.00

## 8/955.701

تیغ اتصال نیم‌گرد

Flute & Bead Set

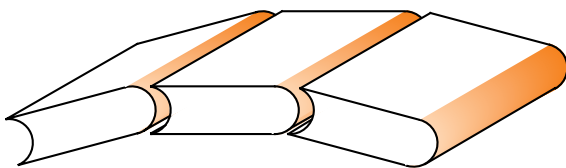
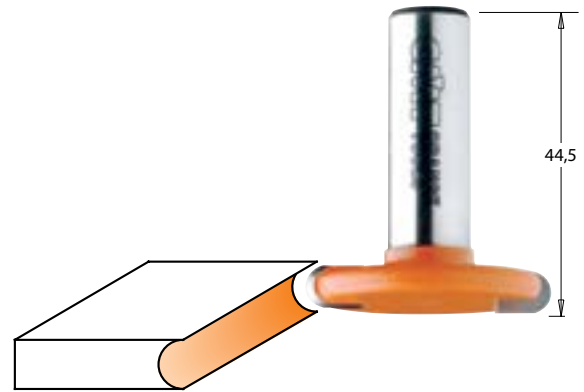
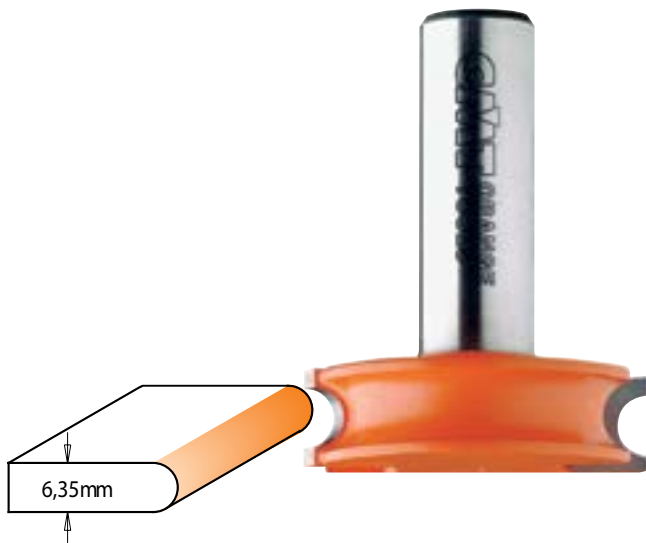

قطر	شعاع انحنا	کد سفارش (S=شفت)
D mm	R mm	ORDER NO S=Ø12mm
38	3,2	955.701.11

## 955

تیغ اتصال (۴۵°)

Lock Miter Bits

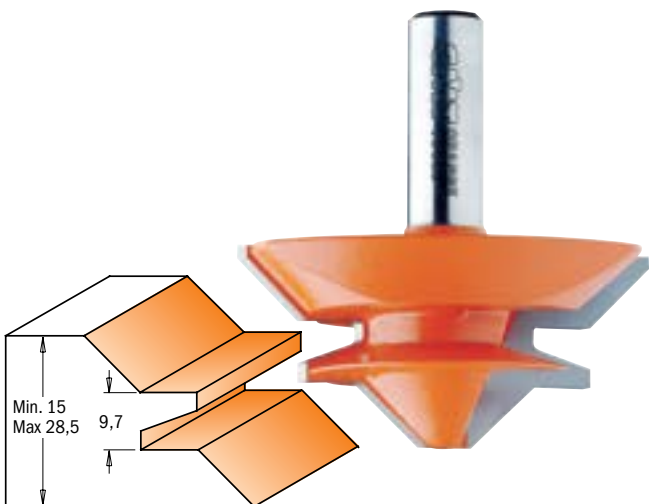

قطر	کارگیر	طول	زاویه برش	کارگیر سنجشی	کد سفارش (S=شفت)
D mm	I mm	L mm	A mm	T1 mm	ORDER NO S=Ø12mm
70	31,7	69,9	45°	15 ÷ 28,5	955.503.11

955

تیغ اتصال افقی لبه

Reverse Glue Joint Bits



قطر	کارگیر	طول	کارگیر ثانویه	کد سفارش (S=شفت)
D mm	I mm	L mm	T1 mm	ORDER NO S=Ø12mm
44,4	32	70,1	15 - 30	955.501.11

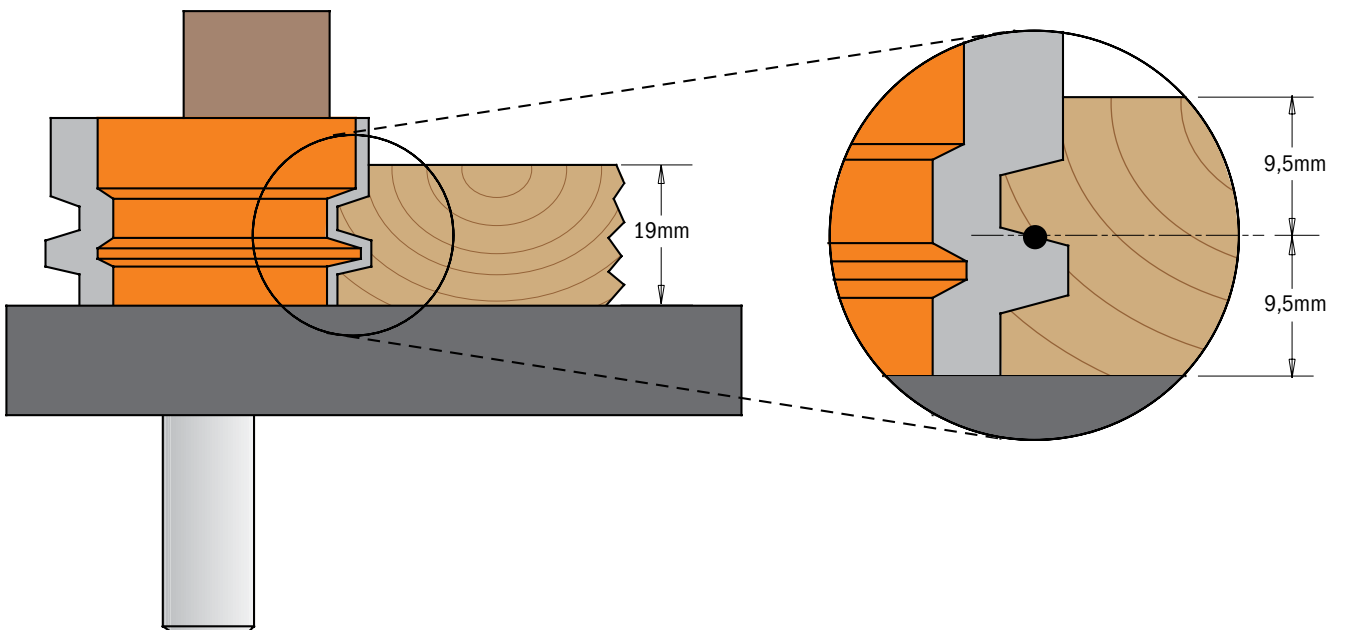
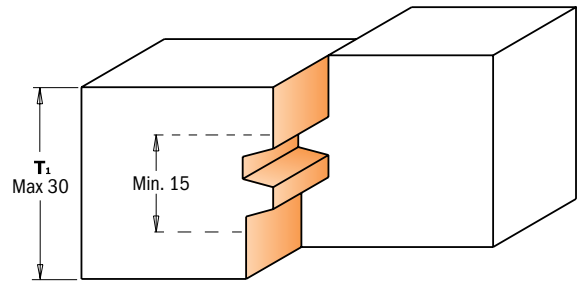

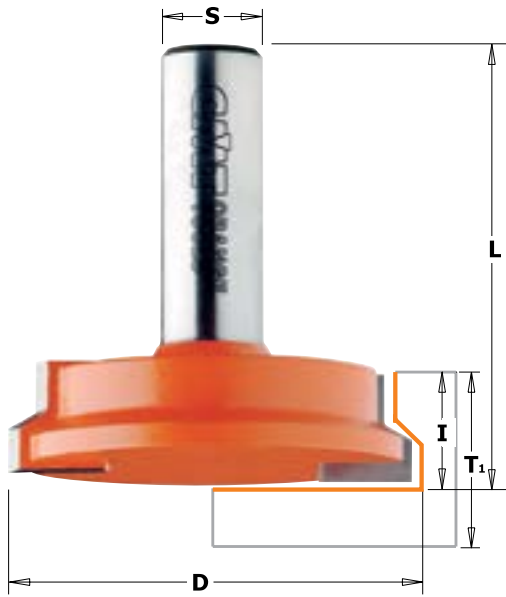

955

تیغ اتصال درآوری کشو

Drawer Lock Bits



قطر D mm	کارگیر l mm	طول L mm	کارگیر سنجشی T1		کد سفارش (شفت=S)	
			min mm	max mm	ORDER NO S=Ø8mm	ORDER NO S=Ø12mm
25,4	12,7	54	9,5	15,87	955.008.11	
31,7	12,7	44,5	15,87	25,4	955.002.11	
50,8	12,7	50,8	15,87	25,4		955.502.11

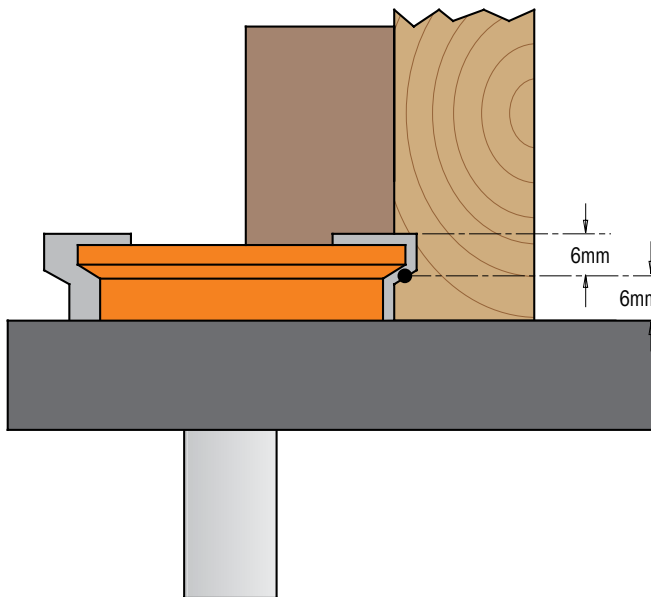
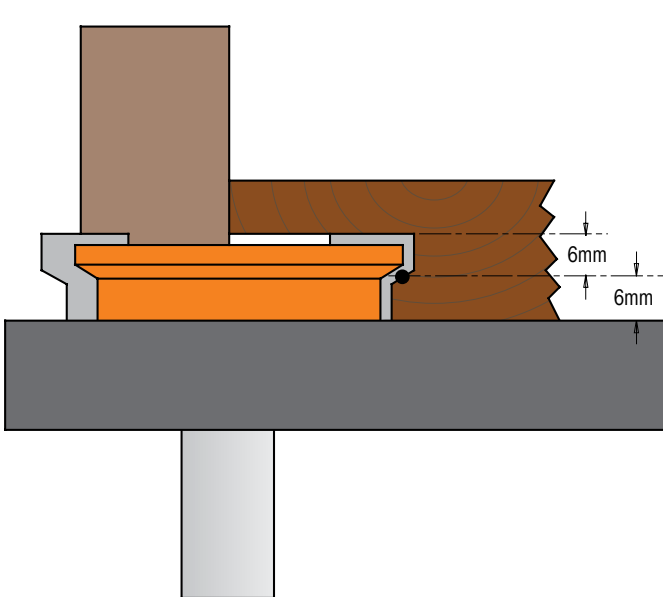
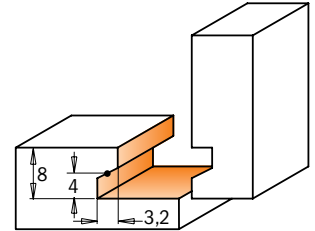
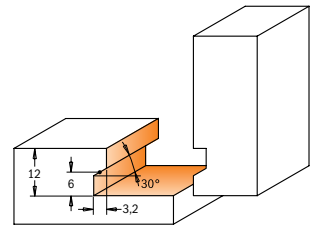



## تیغ ناودانی

Decorative Ogee Bits

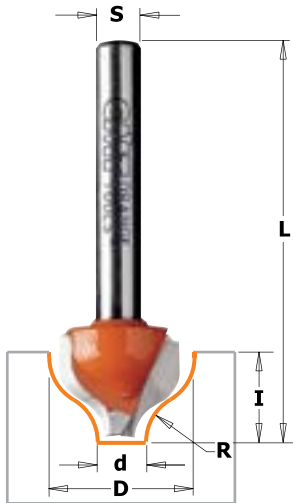

965

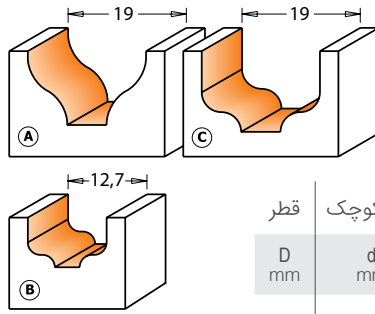

قطر		کارگیر	طول	شعاع انحنا	کد سفارش (شفت=S)	
D mm	d mm	l mm	L mm	R mm	ORDER NO S=Ø8mm	ORDER NO S=Ø12mm
19	6,35	11	50,8	6,4	965.001.11	
12,7	4	8	51	2	965.002.11	
19	6,35	13	68	3,2		965.503.11

965

## تیغ ناودانی

Decorative Beading Bits

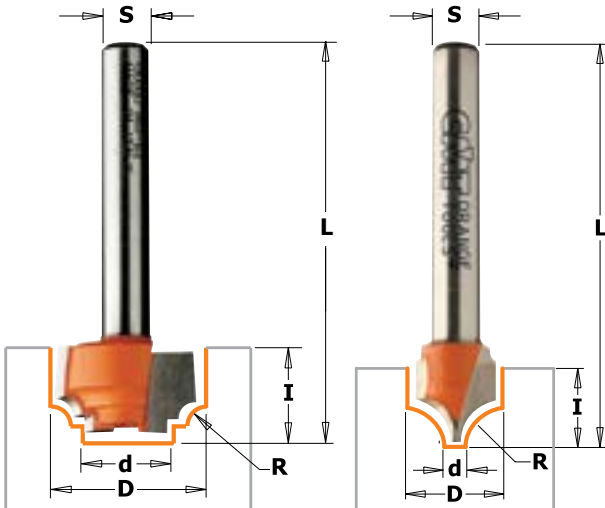

965.1

965.4

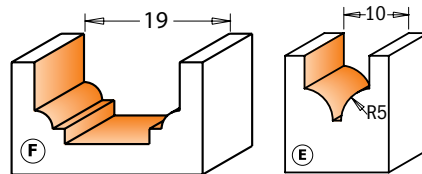

قطر		کارگیر	طول	شعاع انحنا	کد سفارش (شفت=S)	
D mm	d mm	l mm	L mm	R mm	ORDER NO S=Ø8mm	ORDER NO S=Ø12mm
19	11,1	11	50,8	2,4	965.102.11	
10	1,3	10	50	5	965.402.11	

965

## تیغ پروفیل ناودانی

Decorative Ogee Bits

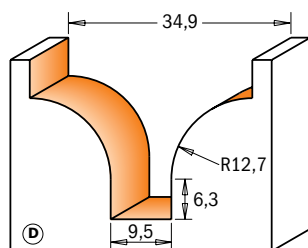

8/965.903  
8/965.904

قطر		کارگیر	طول	شعاع انحنا	کد سفارش (شفت=S)	
D mm	d mm	l mm	L mm	R mm	ORDER NO S=Ø12mm	
25,4	9,5	9,5	49	3,2	965.504.11	
34,9	9,5	25	65,5	12,7	965.904.11	

## 927

### تیغ بانکی CNC

Ovolo Bits

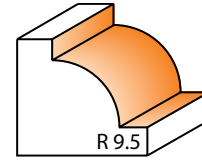
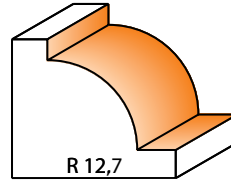
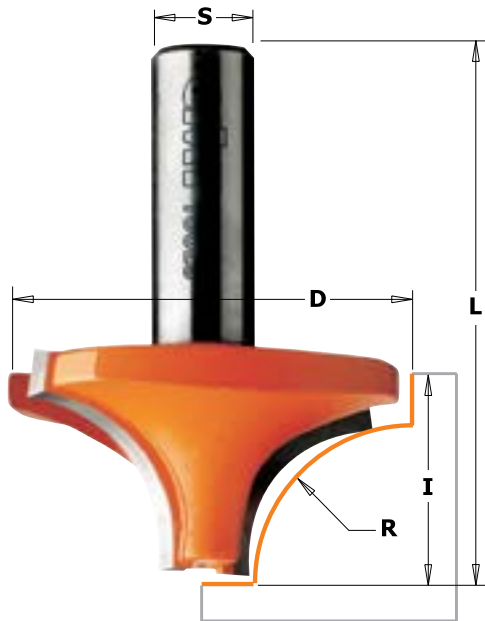

قطر	کارگیر	طول	شعاع انحنا	کد سفارش (S=شفت)	
D mm	I mm	L mm	R mm	ORDER NO S=Ø8mm	ORDER NO S=Ø12mm
38,1	19	57,1	12,7		927.627.11
31,7	15,8	54	9,5		927.595.11
31,7	15,8	47,6	9,5	927.095.11	

## 955

### ست فاق و زبانه

V-Tongue & Groove Set

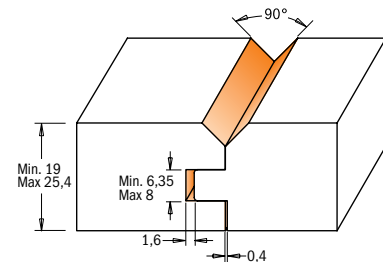
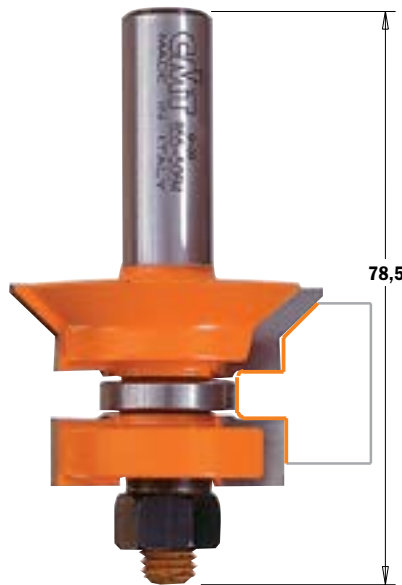
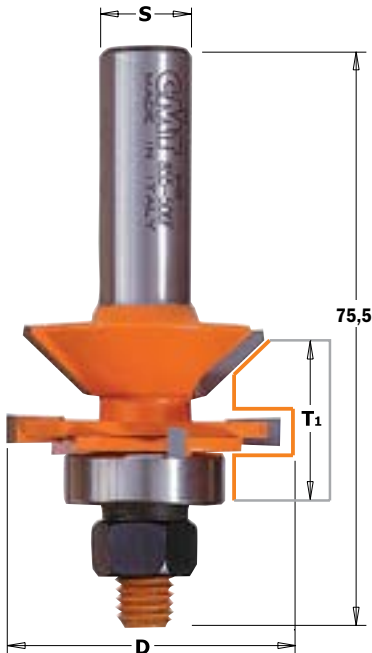

قطر	کارگیر سنجشی	کد سفارش (شفت S)	متعلقات				
D mm	T1 mm	ORDER NO S=Ø12mm	8mm	4mm	19mm	22mm	8mm
44,4	19÷25,4	955.506.11	822.013.11	822.014.11	791.011.00	791.005.00	990.020.00

تیغ پروفیل لبه

Roman Ogee Bits

7/940

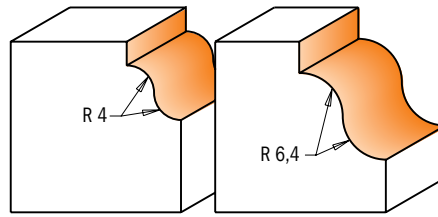

کارگیر			شعاع انحنا (S=شفت)		متعلقات			
قطر	کارگیر	شعاع انحنا	کد سفارش (S=Ø6mm)	کد سفارش (S=Ø8mm)				
D mm	l mm	R mm	ORDER NO S=Ø6mm	ORDER NO S=Ø8mm				
28,7	11,5	4	740.270.11	940.270.11	990.423.00	791.003.00	990.058.00	991.057.00
38,1	17,3	6,4	740.350.11	940.350.11	990.423.00	791.003.00	990.058.00	991.057.00

7/941

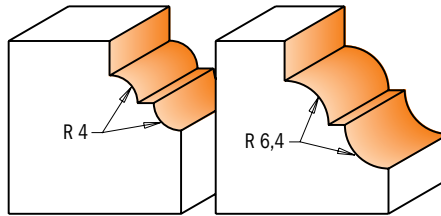

کارگیر			شعاع انحنا (S=شفت)		متعلقات			
قطر	کارگیر	شعاع انحنا	کد سفارش (S=Ø6mm)	کد سفارش (S=Ø8mm)				
D mm	l mm	R mm	ORDER NO S=Ø6mm	ORDER NO S=Ø8mm				
33,4	13	4	741.285.11	941.285.11	990.423.00	791.003.00	990.058.00	991.057.00
42,8	18,5	6,4	741.380.11	941.380.11	990.423.00	791.003.00	990.058.00	991.057.00

7/944

Classical Ogee Bits

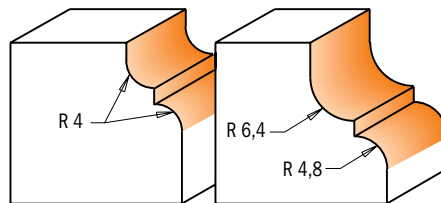

کارگیر			شعاع انحنا (S=شفت)		متعلقات			
قطر	کارگیر	شعاع انحنا	کد سفارش (S=Ø6mm)	کد سفارش (S=Ø8mm)				
D mm	l mm	R mm	ORDER NO S=Ø6mm	ORDER NO S=Ø8mm				
28,7	13	4	744.287.11	944.287.11	990.423.00	791.003.00	991.058.00	991.057.00
35	18,5	6,4-4,8	744.350.11	944.350.11	990.423.00	791.003.00	991.057.00	991.057.00

### 7/946

تیغ پروفیل لبه  
Ogee with Fillet Bits

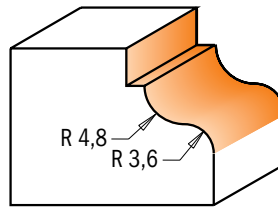

قطر		کارگیر	شعاع انحنای	کد سفارش (شفت=S)		متعلقات			
D mm	I mm	R mm	ORDER NO S=Ø6mm	ORDER NO S=Ø8mm					
34,2	13	4,8-3,6	746.325.11	946.325.11	990.423.00	791.003.00	990.058.00	991.057.00	

### 7/947

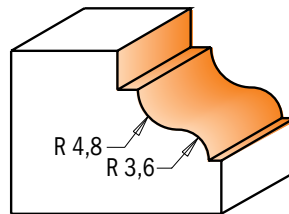

قطر		کارگیر	شعاع انحنای	کد سفارش (شفت=S)		متعلقات			
D mm	I mm	R mm	ORDER NO S=Ø6mm	ORDER NO S=Ø8mm					
34,2	13	4,8-3,6	747.325.11	947.325.11	990.423.00	791.003.00	990.058.00	991.057.00	

### 7/959

Ogee Bits

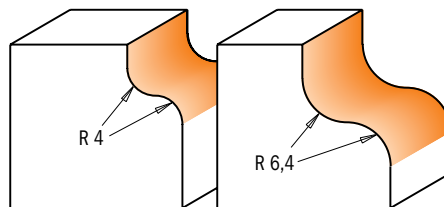

قطر		کارگیر	شعاع انحنای	کد سفارش (شفت=S)		متعلقات			
D mm	I mm	R mm	ORDER NO S=Ø6mm	ORDER NO S=Ø8mm					
28,7	13	4	759.040.11	959.040.11	990.423.00	791.003.00	990.058.00	991.057.00	
38,1	18	6,4	759.064.11	959.064.11	990.423.00	791.003.00	990.058.00	991.057.00	

تیغ اتصال نیم‌گرد

Ovolo Sash Set

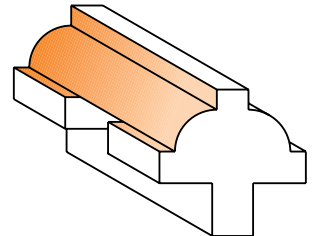
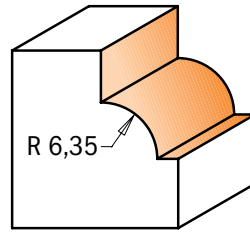
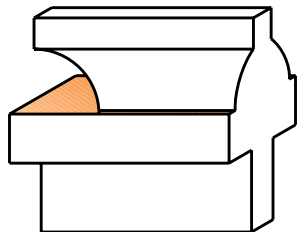
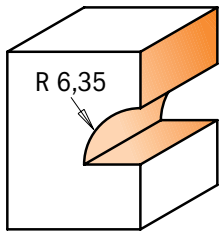
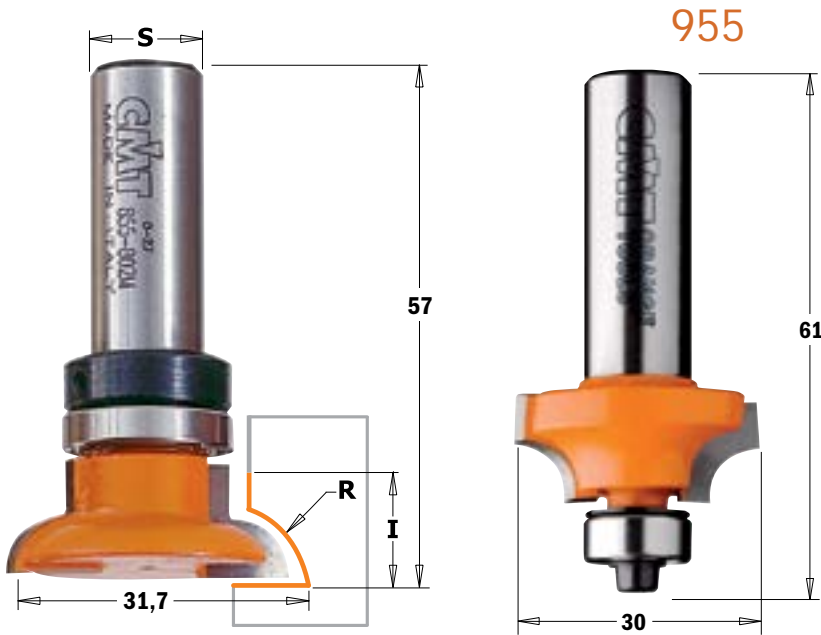

قطر	قطر کوچک	کارگیر	شعاع انحنا	کد سفارش (S=شفت)	متعلقات					
D mm	d mm	l mm	R mm	ORDER NO S=Ø8mm						
31,7	30	12	6,35	955.302.11	990.423.00	791.003.00	990.058.00	991.057.00	791.011.00	541.002.00

703/4/5 - 903/4/5 فرز یخ بدون بلبرینگ

Chamfer Bits

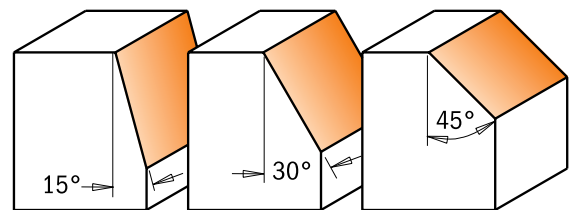
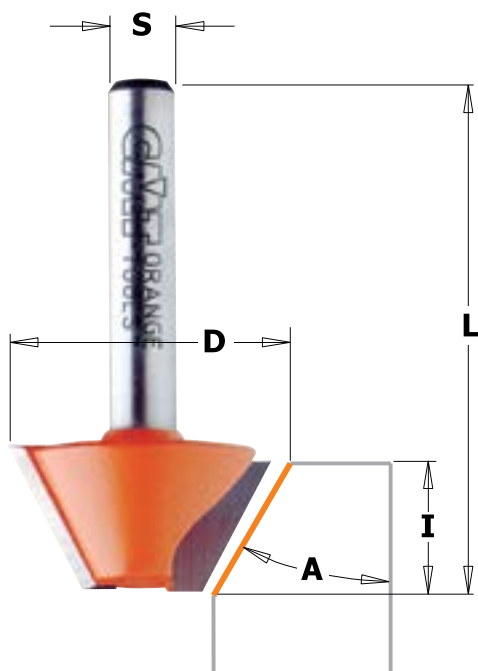

قطر	کارگیر	طول	زاویه برش	کد سفارش (شفت=S)	
D mm	l mm	L mm	A mm	ORDER NO S=Ø6mm	ORDER NO S=Ø8mm
24	14	46	15°	703.240.11	903.240.11
26	12,7	44,5	30°	704.240.11	904.240.11
25	8	41	45°	705.240.11	905.240.11



## 2. Router Bits & Set

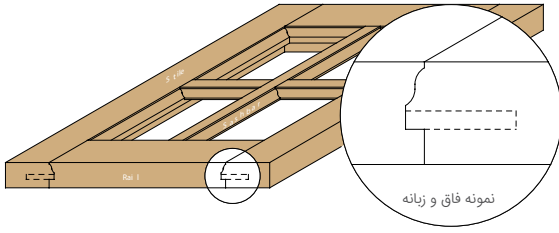

8/955

تیغ قاب پنجره

Window Sash Set

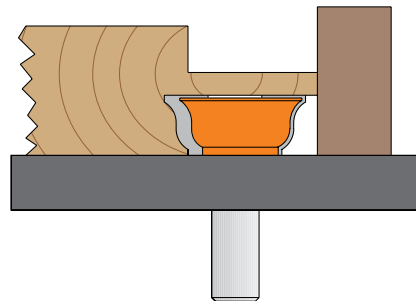
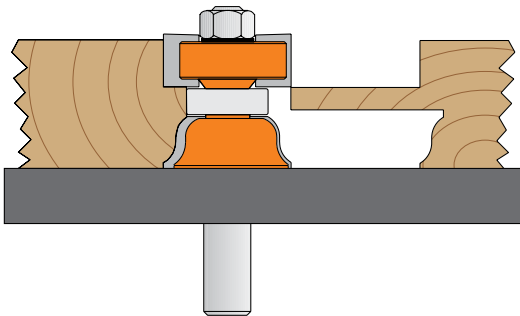
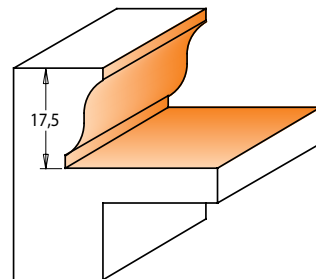
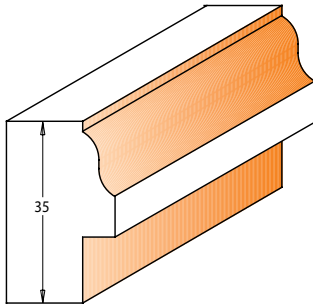
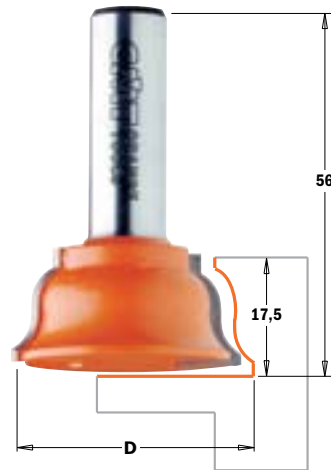
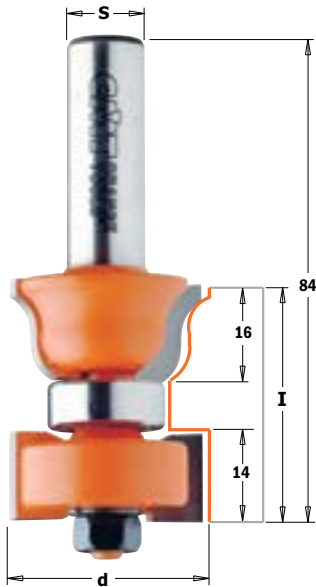
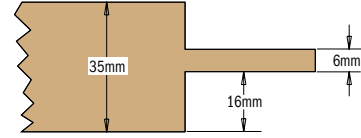

قطر	کارگیر	طول	کد سفارش (شفت=S)	متعلقات			
D mm	l mm	L mm	ORDER NO S=Ø12mm				
35	35	84	955.801.11	791.012.00	822.004.11	541.518.00	990.020.00
38	17,5	56					

970

تیغ پروفیل نفوذی

Stile & Panel Router Bits

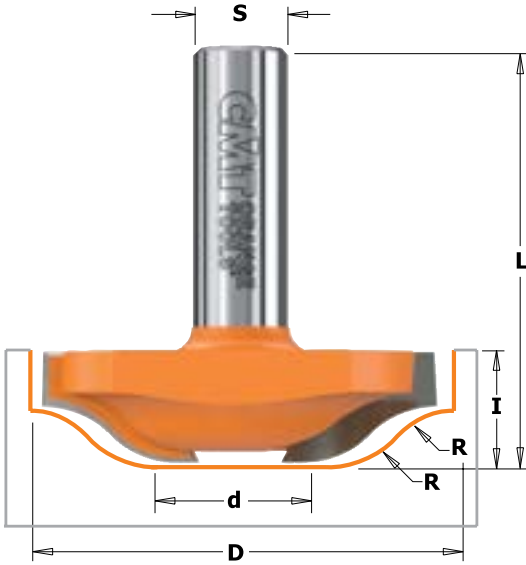

970.501.11

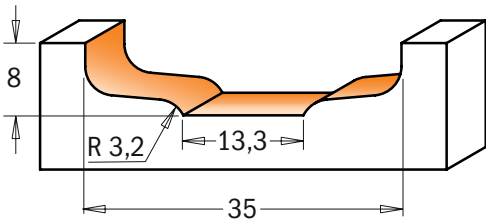

970.505.11

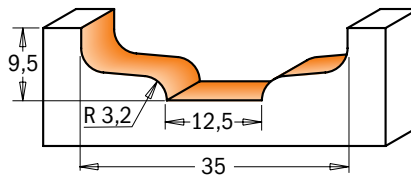

970.504.11

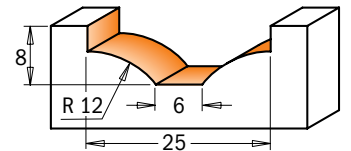

970.101.11

8/970.501.11  
8/970.504.11

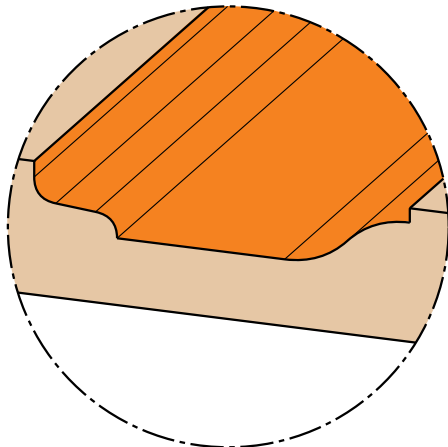

قطر	قطر کوچک	کارگیر	طول	شعاع انحنا	کد سفارش (شفت=S)	
D mm	d mm	l mm	L mm	R mm	ORDER NO S=Ø8mm	ORDER NO S=Ø12mm
25	6	8	39,8	12	970.101.11	
50	16	14	52,1	12		970.501.11
35	12,5	9,5	47,6	3,2		970.504.11
35	13,3	8	46	3,2		970.505.11

955

تیغ نیم‌گرد

Window Sash Set

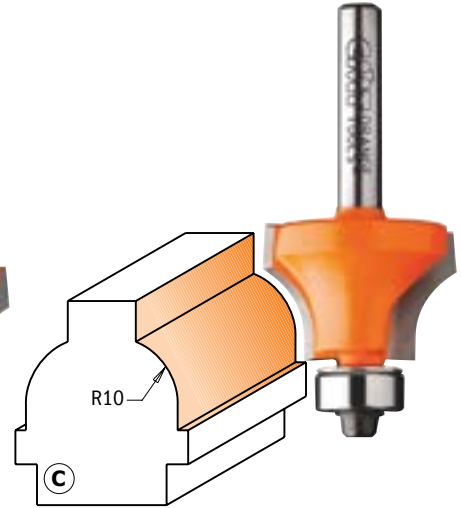
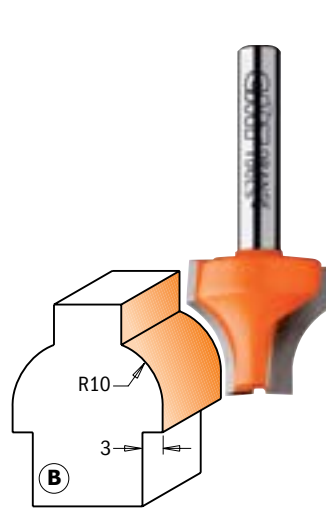
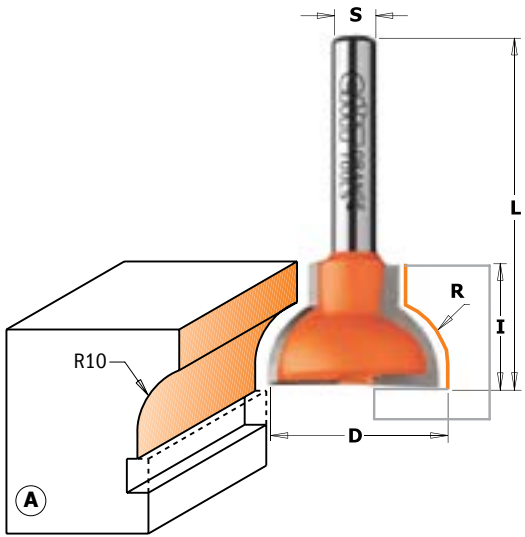

قطر	کارگیر	طول	شعاع انحنای	کد سفارش (S=شفت)	متعلقات			
D mm	I mm	L mm	R mm	ORDER NO S=Ø8mm				
22	19	50,8	10	955.307.11F				
25	19	50,8	10	955.307.11M				
28	19	61,2	10	955.308.11F	990.423.00	791.003.00	990.058.00	991.057.00

955

تیغ دستگیره دراور

Finger Pull Bit

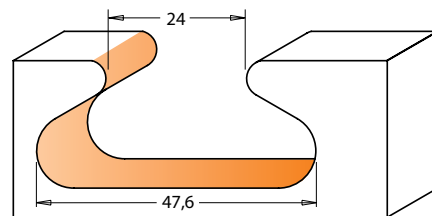
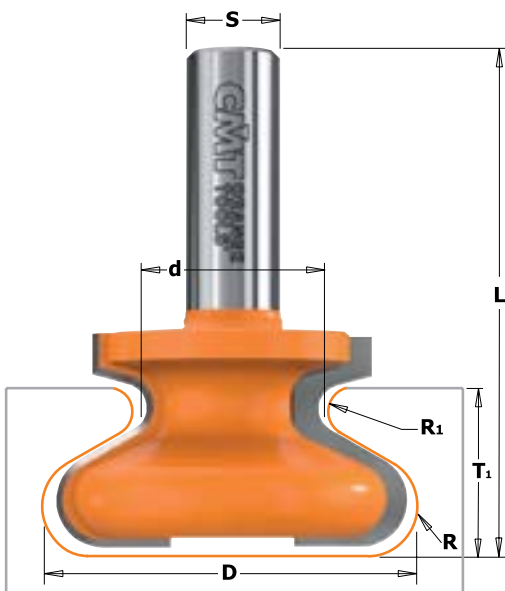

قطر	قطر کوچک	کارگیر	طول	کارگیر سنجشی	شعاع انحنای	شعاع انحنای	کد سفارش (S=شفت)
D mm	d mm	I mm	L mm	T1 mm	R mm	R1 mm	ORDER NO S=Ø12mm
47,6	24	28,5	66,6	22	6,35	3,2	955.601.11



## 955

### تیغ پروفیل لبه

Window Sill & Finger Bits

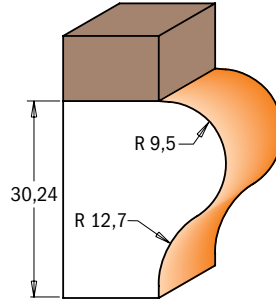
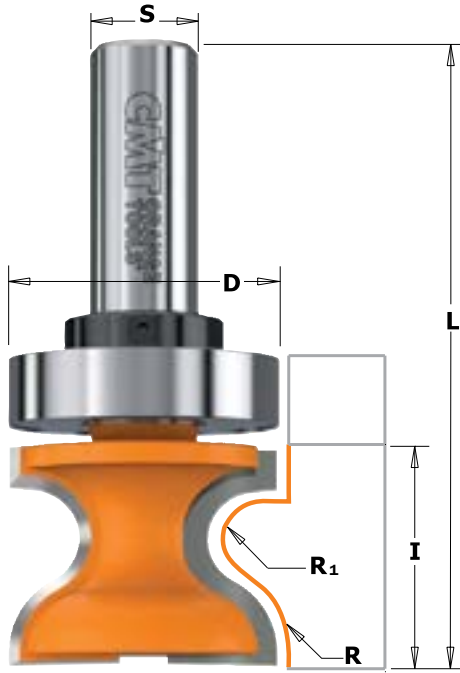

قطر	کارگیر	طول	شعاع انحنا	شعاع انحنا	کد سفارش (S=شفت)
D mm	I mm	L mm	R mm	R1 mm	ORDER NO S=Ø12mm
38,1	35	85,8	12,7	9,5	955.805.11

## 900

### تیغ اتصال فاق و زبانه

Tongue & Groove Set

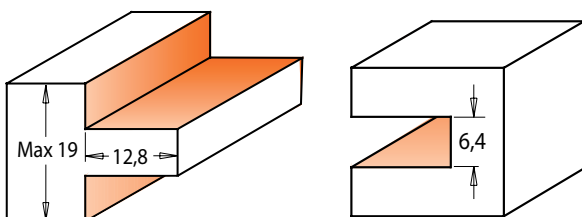
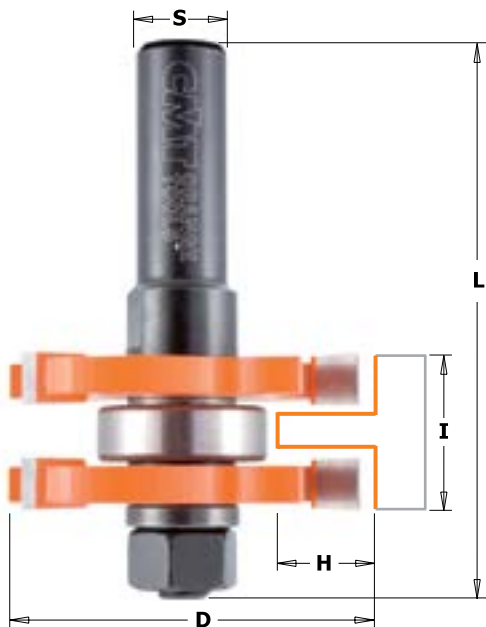

قطر	کارگیر	طول	عمق نفوذ	کد سفارش (S=شفت)	متعلقات
D mm	I mm	L mm	H mm	ORDER NO S=Ø12mm	
47,6	19	71	12,8	900.626.11	
					924.131.00
					791.005.00
					822.364.11
					990.020.00

990

تیغ قرنیز  
Moulding Bits

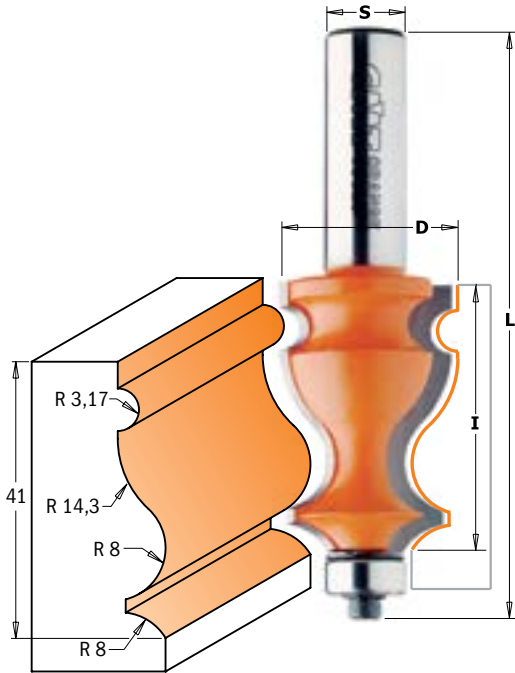

قطر	کارگیر	طول	کد سفارش (S=شفت)	متعلقات			
D mm	I mm	L mm	ORDER NO S=Ø12mm				
27	41	90,2	955.902.11	990.423.00	791.003.00	991.058.00	991.057.00

991

تیغ فاق و زبانه کابینتی  
Rail & Stile Sets

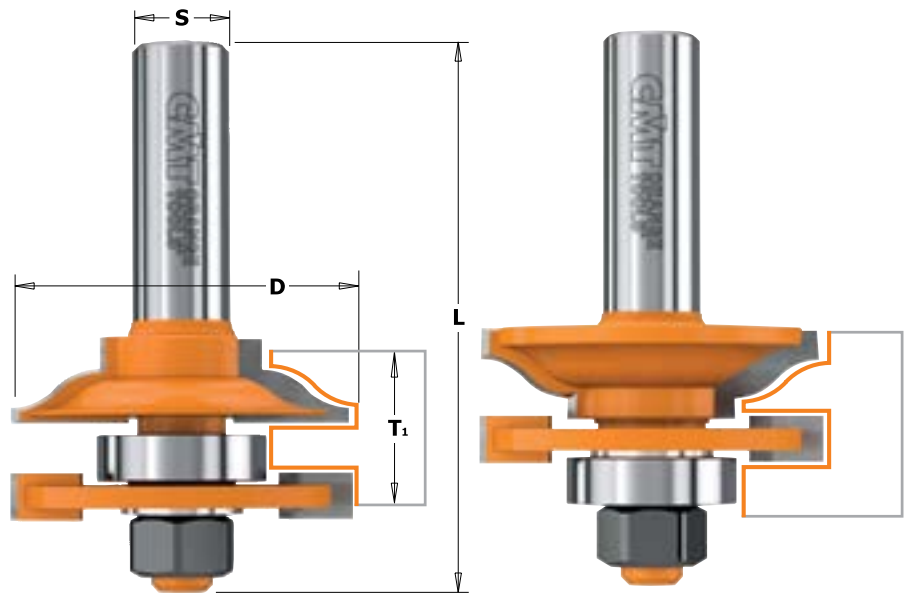
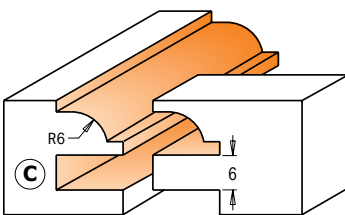
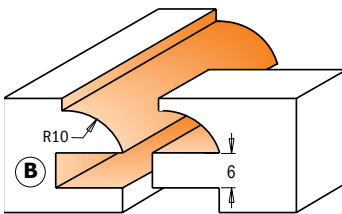
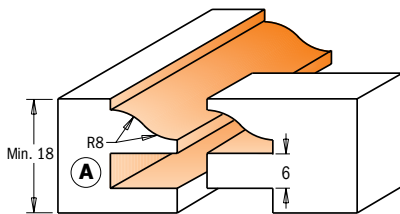

قطر	طول	کارگیر سنجشی	کد سفارش (S=شفت)	متعلقات					
D mm	L mm	T <sub>1</sub> mm	ORDER NO S=Ø12mm			0.1 mm	0.3 mm	0.9 mm	
44,4	71	18 ÷ 22	991.501.11	822.003.11	791.012.00	541.515.00	541.516.00	990.407.00	990.020.00
44,4	71	18 ÷ 22	991.502.11	822.003.11	791.012.00	541.515.00	514.516.00	990.407.00	990.020.00

تیغ حاشیه

Window Sill & Finger Bits

961

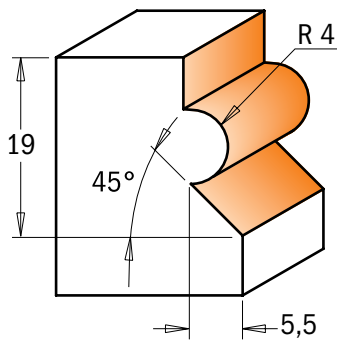
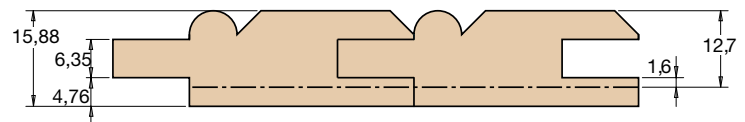
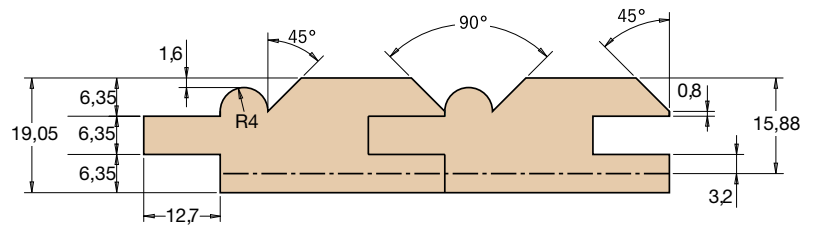
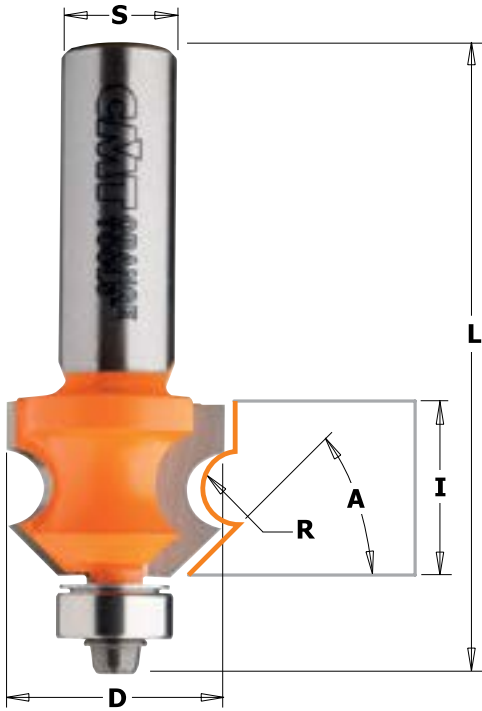

قطر		کارگیر	طول	شعاع انحنای	کد سفارش (S=شفت)	متعلقات			
D mm	I mm	L mm	R mm	ORDER NO S=Ø12mm					
23,8	19,05	67,7	4	961.601.11	990.423.00	791.003.00	990.058.00	991.057.00	

950

مته جا کلید

Keyhole Bits

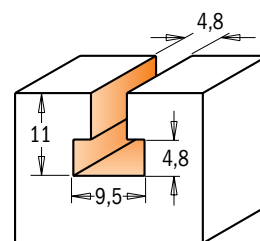

قطر	قطر کوچک	کارگیر	طول	کد سفارش (S=شفت)
D mm	d mm	I mm	L mm	ORDER NO S=Ø8mm
9,5	4,8	11	54	950.001.11

935

دوراهه همراه ست بلبرینگ

Rabbeting Sets



قطر	کارگیر	عمق نفوذ	کد سفارش (S=شفت)
D mm	I mm	H mm	ORDER NO S=Ø12mm
34,9	19	0-12,7	935.502.11

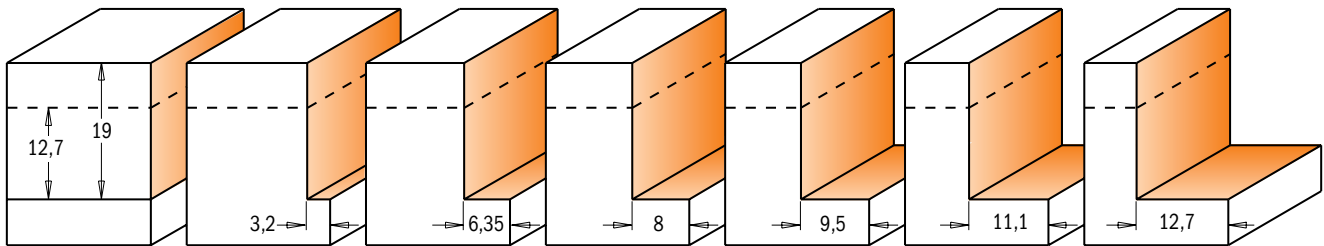

900

تیغ اتصال انگشتی

Professional Finger Joint Bit

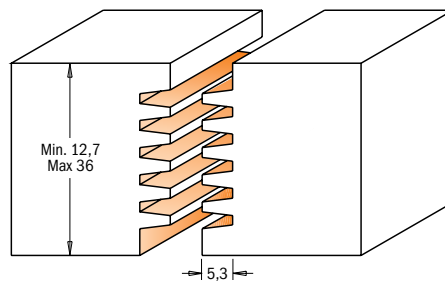
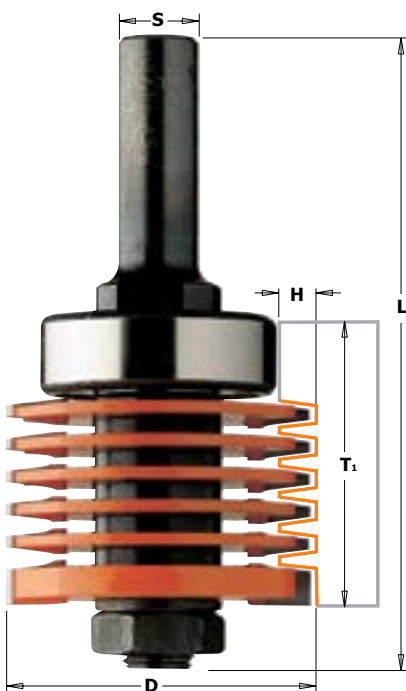

قطر	طول	کارگیر سنجشی	عمق نفوذ	کد سفارش (S=شفت)	متعلقات			
D mm	L mm	T1 mm	H mm	ORDER NO S=Ø12mm				
47,6	97	12,7 - 36	5,5	900.606.11	924.130.00	791.027.00	822.340.11	990.020.00
47,6	97	12 - 40	9,5	900.616.11	824.130.00	791.027.00	822.340.11	990.020.00

# 956

تیغ لبه میز

Table Edge & Hand Rail Bits

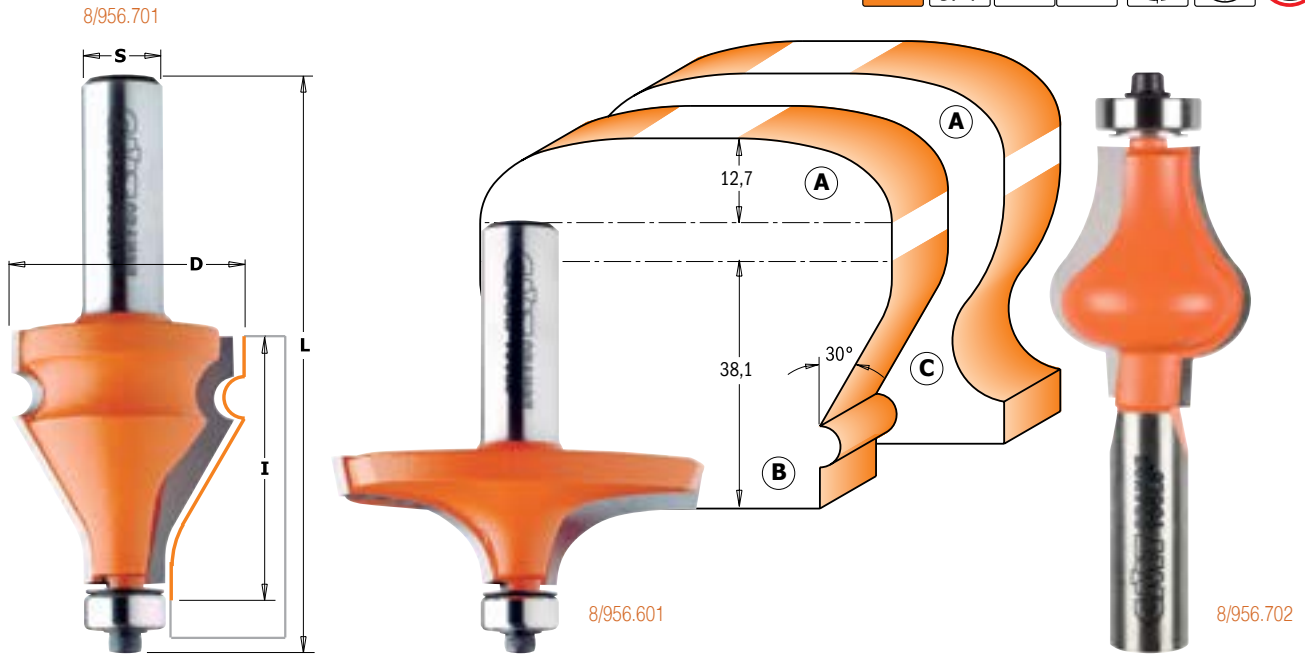

قطر	کارگیر	طول	کد سفارش (شفت=S)	متعلقات			
D mm	I mm	L mm	ORDER NO S=Ø12mm				
63,5	19	67,9	956.601.11	990.423.00	791.003.00	990.058.00	991.057.00
35	38	87	956.701.11	990.423.00	791.003.00	990.058.00	991.057.00
31,7	38,1	87	956.702.11	990.423.00	791.018.00	990.058.00	991.057.00

# 913

شیارزن خزینه

Screw Slot Bits

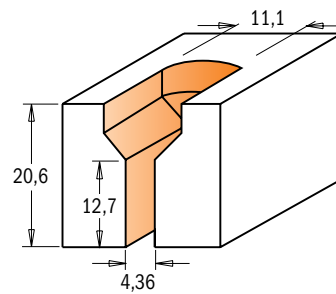
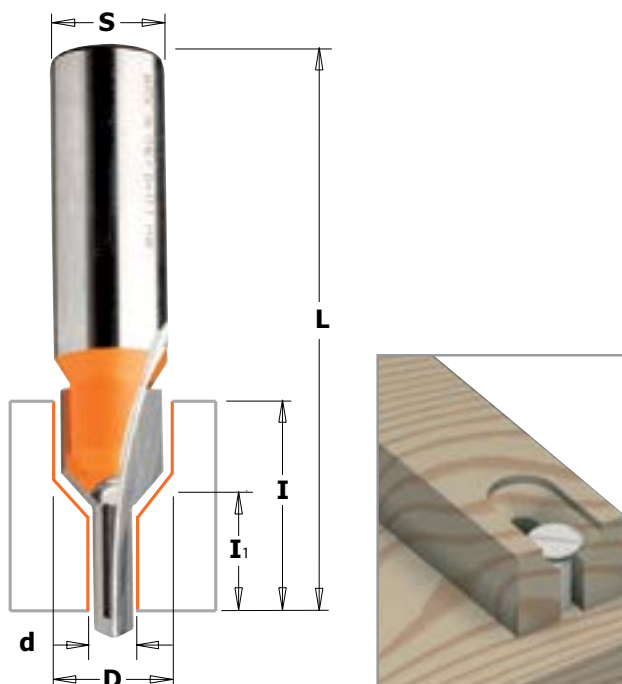

قطر	قطر کوچک	کارگیر	کارگیر اولیه	طول	کد سفارش (شفت=S)
D mm	d mm	I mm	I1 mm	L mm	ORDER NO S=Ø8mm
11,1	4,36	20,6	12,7	63,5	913.201.11

## 2. Router Bits & Set

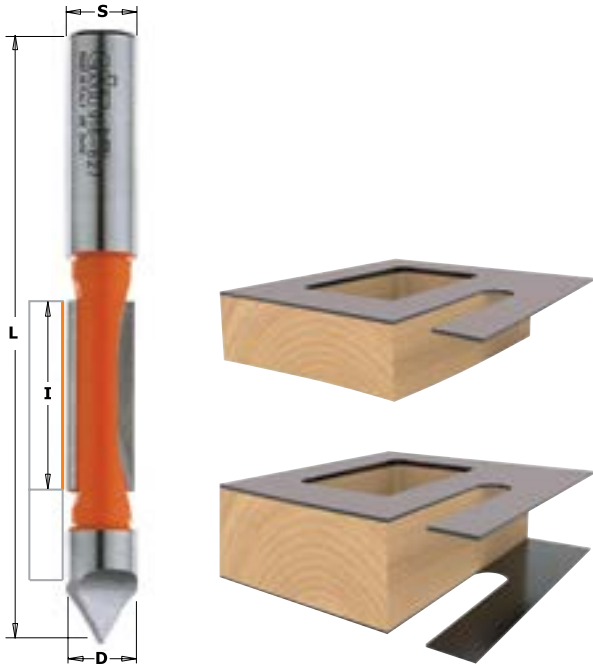

916

مته جاشیشه

Panel Pilot Bits with Guide



قطر	کارگیر	طول	تعداد تیغه	کد سفارش (شفت=S)
D mm	I mm	L mm	Z	ORDER NO S=Ø8mm
8	19	64	1	916.080.11

شیارزن انگستی 751/914/951/199/914

Round Nose Bits

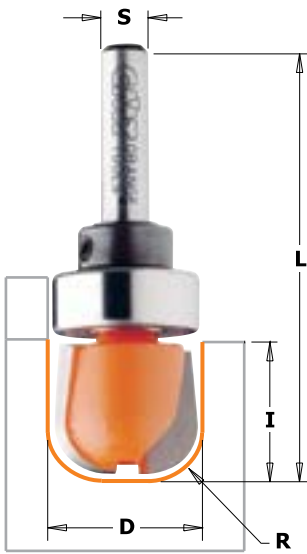

7/851B



7/8/914



7/8/951







قطر	کارگیر	طول	شعاع انحنا	کد سفارش (شفت=S)			متعلقات		
				ORDER NO S=Ø6mm	ORDER NO S=Ø8mm	ORDER NO S=Ø12mm			
12	35	80	6			199.120.11			
15,8	9,5	50,8	8		914.160.11				
19	16	54	6,4	751.002.11	951.002.11				
19	16	54	6,4	751.002.11B			791.007.00	541.003.00	991.056.00
25,4	31,7	73	12,7			914.754.11			
31,7	18,5	58,8	16			914.817.11			
38,1	31,7	69,8	19,05			914.880.11			
50,8	31,7	69,8	25,4			914.990.11			

980

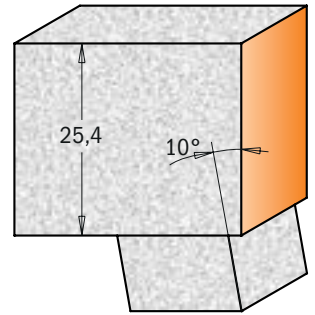
تیغ پرداخت کورین

Solid Surface Sink & Trim Bits



قطر	کارگیر	طول	زاویه برش	کد سفارش (S=شفت)	متعلقات
D mm	I mm	L mm	A mm	ORDER NO S=Ø12mm	  
22	25,4	78	10°	980.572.11	791.048.00 990.058.00 991.057.00

980

فرز کورین مدل سه پله

Solid Surface Decorative Edge Profile Bits

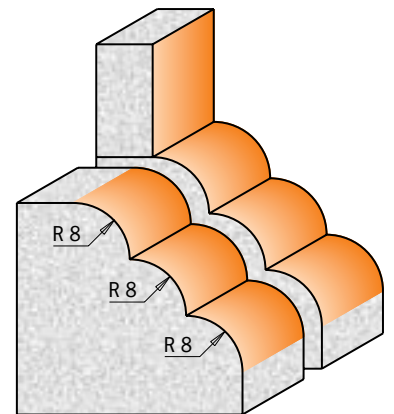
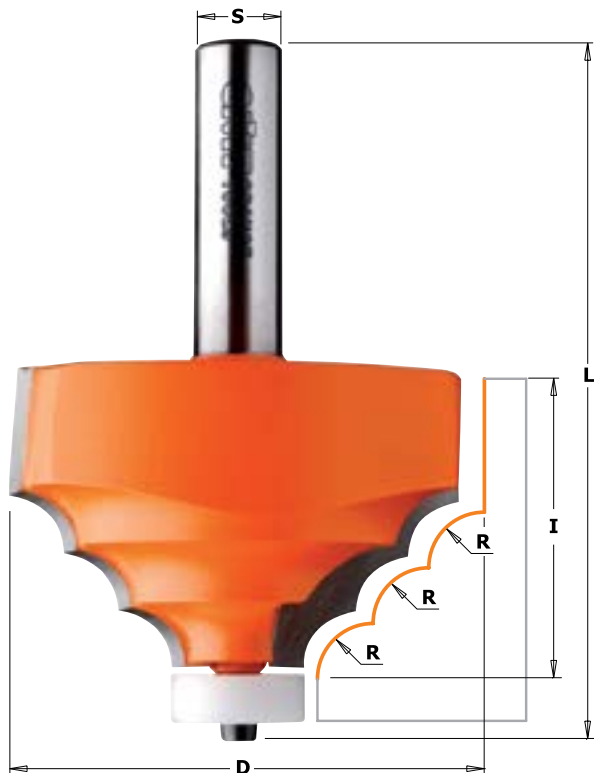

قطر	کارگیر	طول	شعاع انحنای	کد سفارش (S=شفت)	متعلقات
D mm	I mm	L mm	R mm	ORDER NO S=Ø12mm	  
66,7	41,3	89,8	8	980.521.11	791.046.00 990.058.00 991.057.00

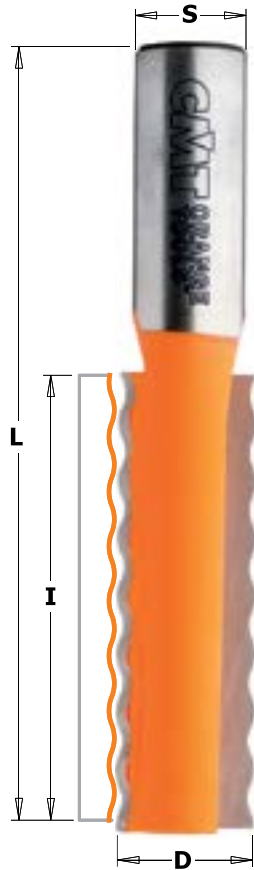

981

تیغ اتصال کورین

Solid Surface Wavy Joint Bit

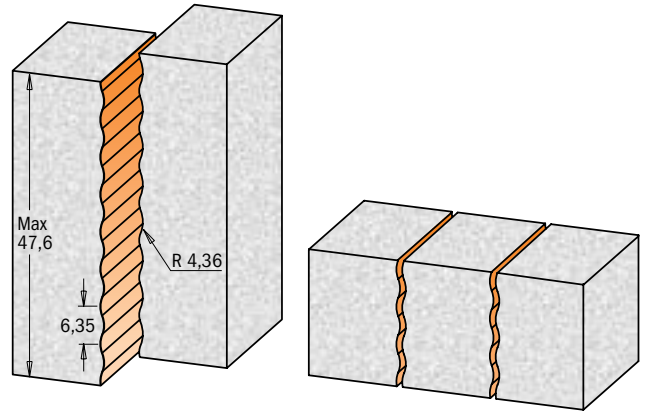

قطر	کارگیر	طول	شعاع انحنا	کد سفارش (شفت=S)
D mm	I mm	L mm	R mm	ORDER NO S=Ø12mm
15,87	51,5	89	4,36	981.531.11

980

تیغ دوراهه کورین

Solid Surface - Inlay Bits

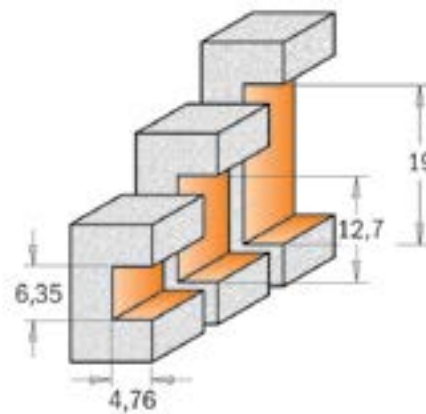
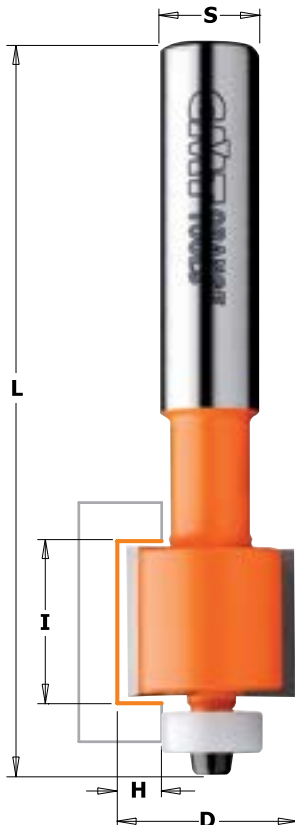

قطر	کارگیر	طول	عمق نفود	کد سفارش (شفت=S)	متعلقات		
D mm	I mm	L mm	H mm	ORDER NO S=Ø12mm			
22,2	12,7	90	4,76	980.512.11	791.044.00	990.058.00	991.057.00
22,2	19,05	90	4,76	980.513.11	791.044.00	990.058.00	991.057.00



پک دوراهه

The CMT Grand Rabbit Set

935



935.990.11



توضیحات	کد سفارش
Description	ORDER NO
کیت کامل دوراهه	935.503.11

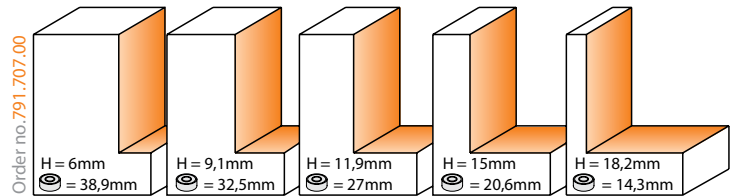
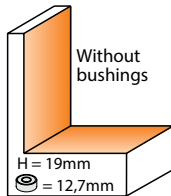
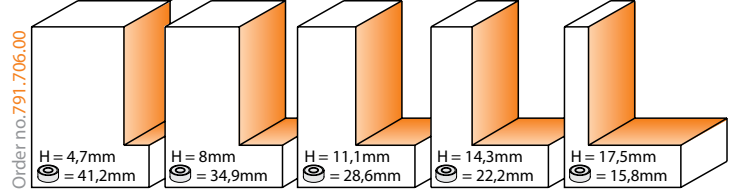
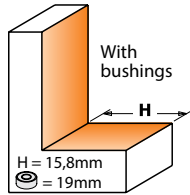
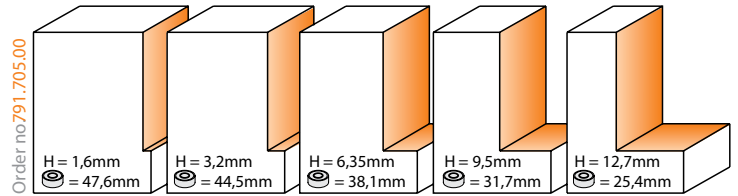
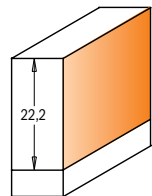

تیغ دوراهه

Rabbeting Bits

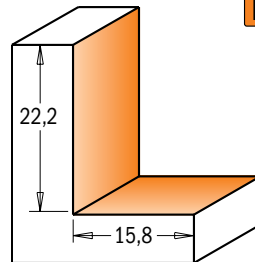

قطر	کارگیر	طول	عمق نفود	کد سفارش (S=شفت)	متعلقات		
D mm	I mm	L mm	H mm	ORDER NO S=Ø12mm			
50,8	22,2	77,8	15,8	935.990.11	990.408.00	791.010.00	990.058.00

# ۳

## توپی‌ها

### Tools with Bore & Kinves

۵۵	توپی زنبوری
۵۵	تیغ پرداخت و دوراهه کن
۵۶	توپی شیارزن متغیر
۵۶	توپی قاب تونیک
۵۷	توپی پخ ۴۵°
۵۷	توپی اتصال انگشتی
۵۸	توپی لبه‌گرد
۵۸	توپی پرداخت مدرج
۵۹	توپی اتصال عرضی
۵۹	توپی اتصال ۴۵°
۶۰	توپی فاق و زبانه دو طرفه
۶۰	توپی فاق و زبانه یک طرفه
۶۱	توپی چند کاره
۶۱	توپی شیارزن متغیر
۶۲	کیت توپی چند کاره
۶۳-۷۶	تیغ توپی چند کاره



## 694-019

توپی زنبوری  
Planing & Jointing Spiral Cutter Heads

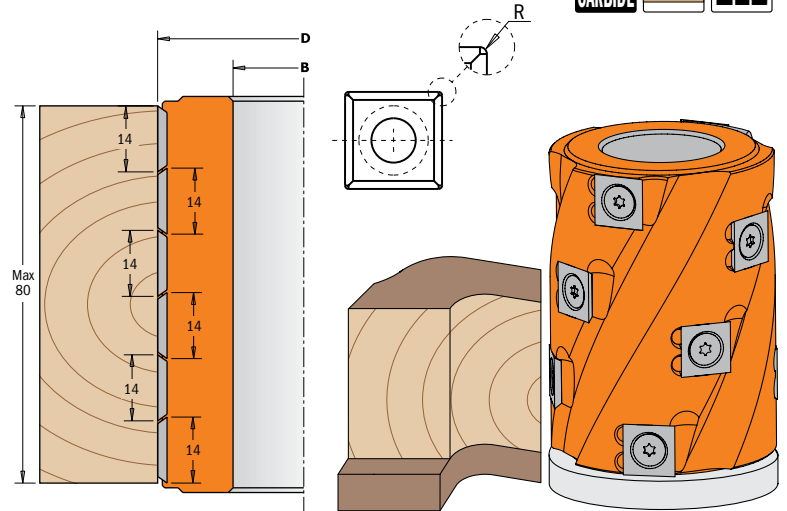
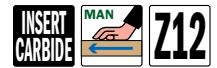

790.140.20  
14x14x2mm

Optional bearing

قطر	شفت	کارگیر	تعداد تیغه	دور در دقیقه	کد سفارش	متعلقات		
D mm	B mm	l mm	Z	RPM mm	ORDER NO			
62	35	80	12	8000~12000	694.019.35	790.140.00	990.093.00	991.073.00

## 694.100

توپی پرداخت و دوراه کن  
Rabbeting Cutter Heads

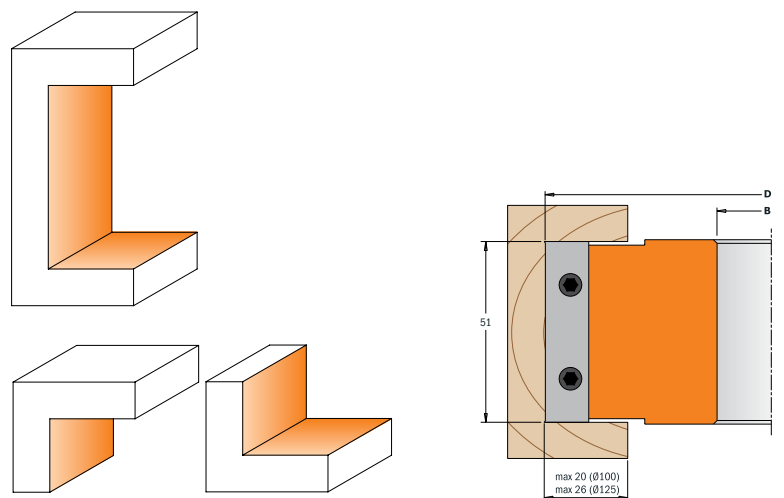
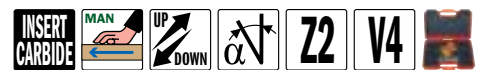

قطر	شفت	کارگیر	تعداد تیغه و تیغه جانبی	دور در دقیقه	کد سفارش	متعلقات						
D mm	B mm	l mm	Z+V	RPM mm	ORDER NO							
100	35	51	2+4	7500~12500	694.100.35	790.140.00	990.093.00	991.073.00	790.500.00	695.999.46	990.064.00	991.064.00



### 3. Tools with Bore & Kinves



## 694.021-694.022 توپی شیازن متغیر

2 Piece Adjustable Grooving Sets

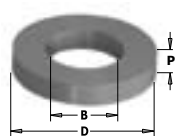

پوش تبدیل برای ضخامت‌های 14 میلیمتر  
Drawing is 1:1 scale

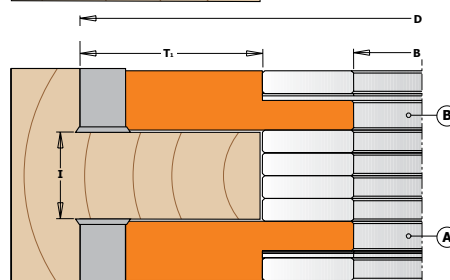
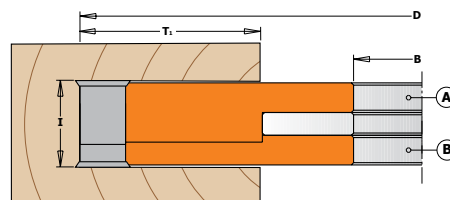
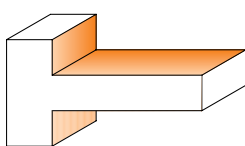
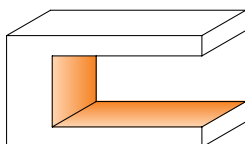

قطر	شفت	کارگیر	مقدار نفوذ	تعداد تیغه و تیغه جانبی	دور در دقیقه	کد سفارش	متعلقات				
D mm	B mm	l mm	T1 mm	Z+V	RPM mm	ORDER NO					
150	35	14-27	44	4+4	5000~8000	694.021.35	790.136.00	990.093.00			695.998.43
170	35	20-39	54	4+4	4400~7400	694.022.35	790.140.00	990.093.00	790.195.12	990.094.00	695.998.48

## 694.012 توپی قاب تونیک

Raised Panel Cutter Heads

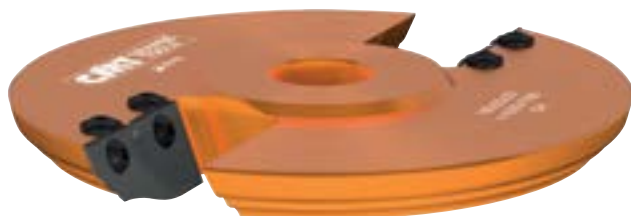

Standard  
Pair of knives 695.012A

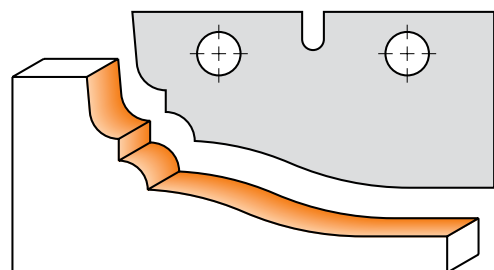
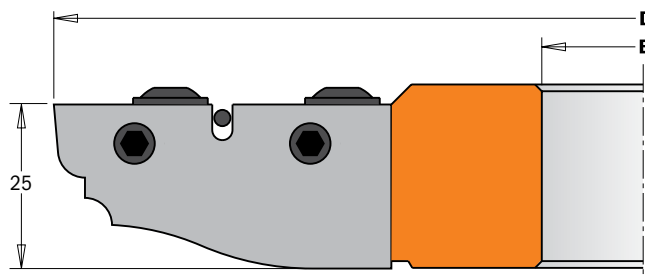

قطر	شفت	کارگیر	تعداد تیغه	دور در دقیقه	کد سفارش	متعلقات		
D mm	B mm	l mm	Z	RPM mm	ORDER NO			
180	35	25	2	4200~7000	694.012.35	695.012A	990.107.00	991.067.00



694.002

توپی پخ ۴۵°  
45° Chamfer Cutter Heads

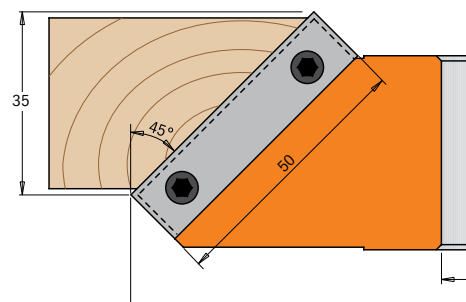
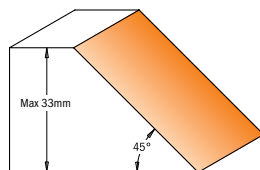
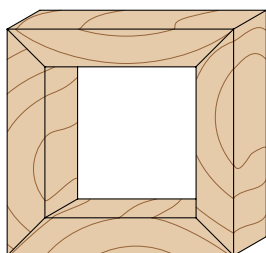

قطر	شفت	کارگیر	تعداد تیغه	دور در دقیقه	کد سفارش	متعلقات			
D mm	B mm	I mm	Z	RPM mm	ORDER NO				
150	35	35	2	5100-8800	694.002.35	790.500.00	695.999.42	990.064.00	991.064.00



694.008

توپی اتصال انگشتی  
Professional Finger Joint Cutter Heads

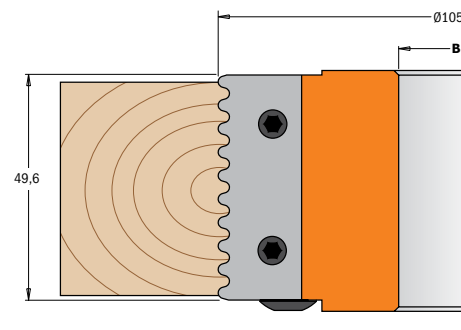
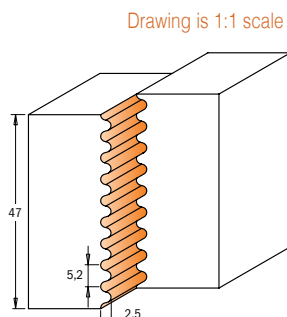

قطر	شفت	تعداد تیغه	دور در دقیقه	کد سفارش	متعلقات			
D mm	B mm	Z	RPM mm	ORDER NO				
105	35	2	7300-11500	694.008.35	695.008.10	695.999.49	990.064.00	991.064.00







### 3. Tools with Bore & Kinves

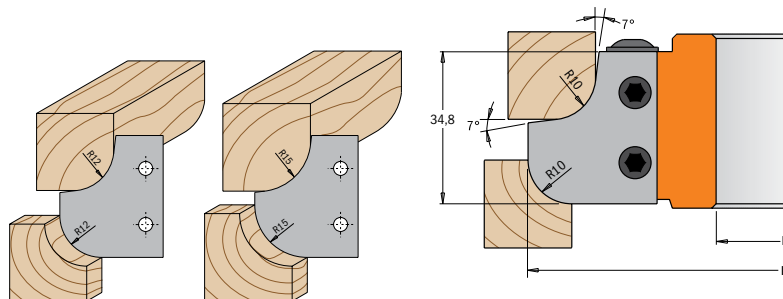

694.007

تویی لبه گرد  
Roundover & Cove Cutter Heads





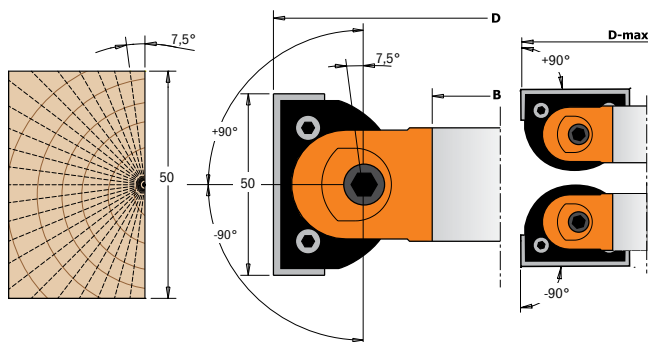

قطر	شفت	تعداد تیغه	دور در دقیقه	کد سفارش	متعلقات			
D mm	B mm	Z	RPM mm	ORDER NO	 x2			
121	35	2	6300~10500	694.007.35	695.007.10	695.999.31	990.064.00	991.064.00

694.077

تویی پرداخت مدرج  
Professional Adjustable Chamfer Cutter Heads with Gear Box



قطر	شفت	کارگیر	تعداد تیغه	حداکثر قطر	دور در دقیقه	کد سفارش	متعلقات				
D mm	B mm	l mm	Z	D_Max 45°mm	RPM mm	ORDER NO					
160	35	50	2	183	4800~6000	694.017.35	695.017.01	790.500.00	695.999.48	990.106.00	991.067.00





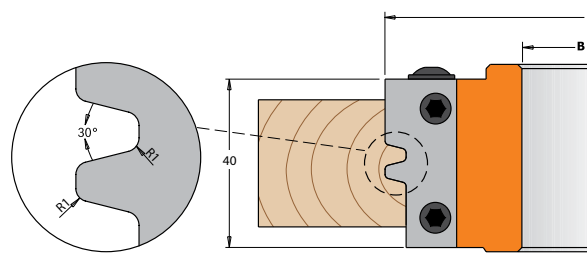
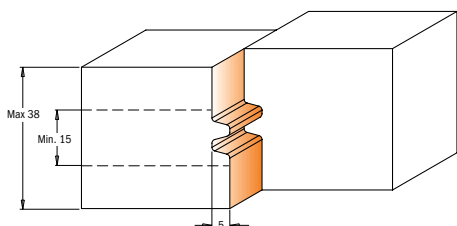

694.009

توپی اتصال عرضی

Reverse Glue Joint Cutter Heads



Spare parts

قطر	شفت	تعداد تیغه	دور در دقیقه	کد سفارش	متعلقات			
D mm	B mm	Z	RPM mm	ORDER NO	 x2			
100	35	2	7500-12500	694.009.35	695.009.01	695.999.38	990.064.00	991.064.00

694.001

توپی اتصال ۴۵°

45° Lock Miter Cutter Heads

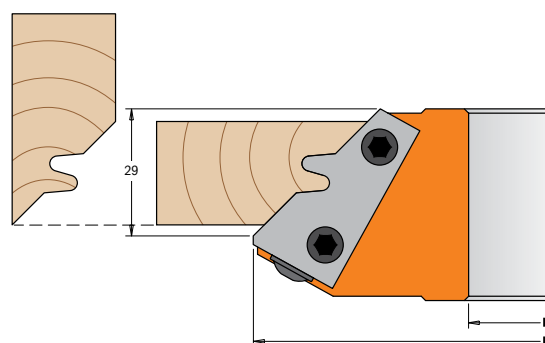
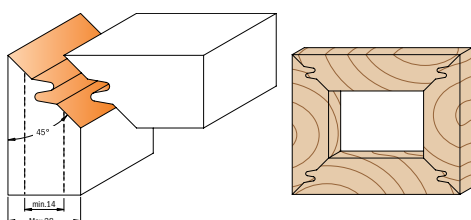

قطر	شفت	تعداد تیغه	دور در دقیقه	کد سفارش	متعلقات			
D mm	B mm	Z	RPM mm	ORDER NO	 x2			
140	35	2	5500-9500	694.011.35	695.011.01	695.999.42	990.064.00	991.064.00



### 3. Tools with Bore & Kinves

## 694.015

### تویی فاق و زبانه دو طرفه (درب)

### Profile & Counter Profile Cutter Head Sets

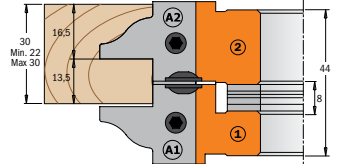
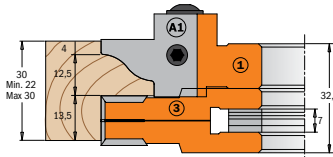
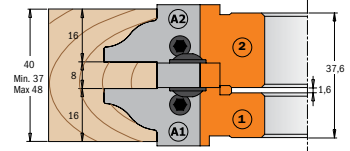
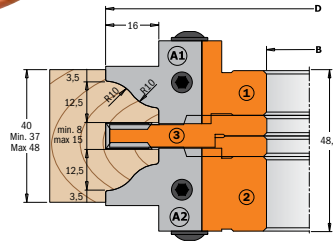





قطر	شفت	تعداد تیغه و تیغه جانبی	دور در دقیقه	کد سفارش	متعلقات
D mm	B mm	Z+V	RPM mm	ORDER NO	  
132	35	2+4	5700-9500	694.015.35	695.998.03 695.998.23 695.998.35

## 694.014

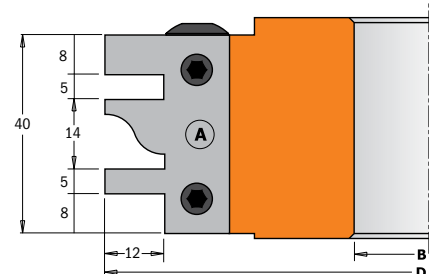
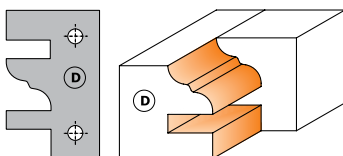
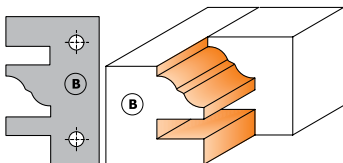
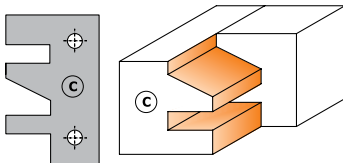
### تویی فاق و زبانه یک طرفه (کابینت)

### 1 Piece Rail & Stile Cutter Heads



قطر	شفت	تعداد تیغه	دور در دقیقه	کد سفارش	متعلقات
D mm	B mm	Z	RPM mm	ORDER NO	 x2   
120	35	2	6400-10500	694.014.35	695.014A 695.999.39 990.066.00 991.067.00





692

توپی چندکاره

Cutter Heads without Limiters

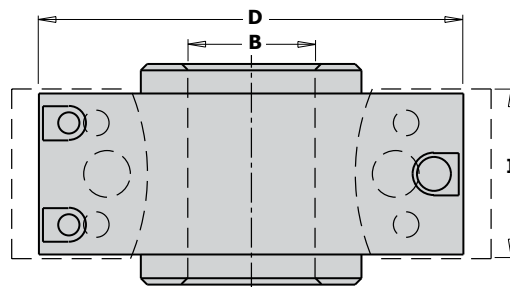
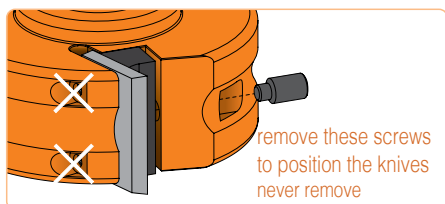
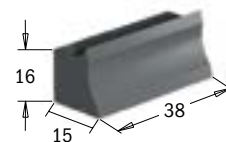

قطر	شفت	تعداد تیغه	دور در دقیقه	کد سفارش	متعلقات
D mm	B mm	I	RPM mm	ORDER NO	
100	35	40-50	5500~8400	692.100.35	692.999.01 990.064.00 991.064.00

964.001

توپی شیازن متغیر

3 piece Adjustable Grooving Sets

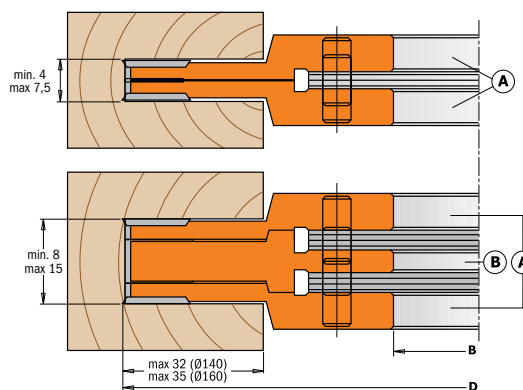
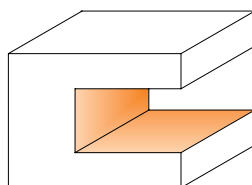
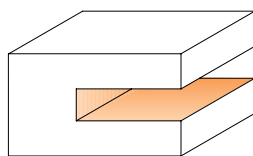

قطر	شفت	تعداد تیغه و تیغه جانبی	دور در دقیقه	کد سفارش	متعلقات
D mm	B mm	Z+V	RPM mm	ORDER NO	
140	35	4+4	5500~9500	694.001.35	790.181.00 790.140.10 790.076.00 695.998.23



### 3. Tools with Bore & Kinves



692

کیت توپی چندکاره

13 Piece Multiprofile Cutter Head Sets without Limiters

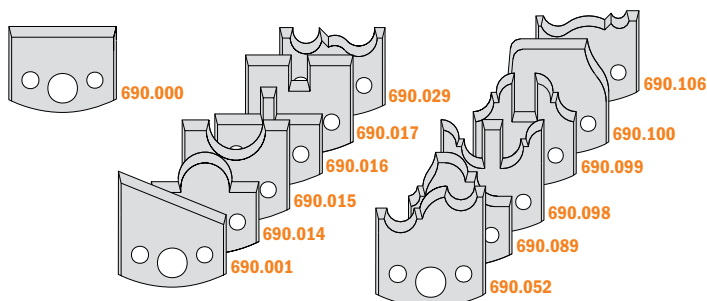

قطر	شفت	ارتفاع تیغه	دور در دقیقه	کد سفارش	متعلقات		
D mm	B mm	I mm	RPM	ORDER NO			
100	35	40	5500~8400	692.013.03	692.999.01	990.064.00	991.064.00

692

کیت توپی چندکاره

13 Piece Multiprofile Cutter Head Sets without Limiters

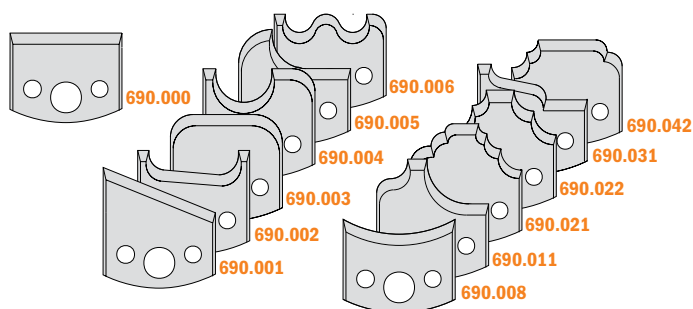

قطر	شفت	ارتفاع تیغه	دور در دقیقه	کد سفارش	متعلقات		
D mm	B mm	I mm	RPM	ORDER NO			
100	35	40	5500~8400	692.013.07	692.999.01	990.064.00	991.064.00

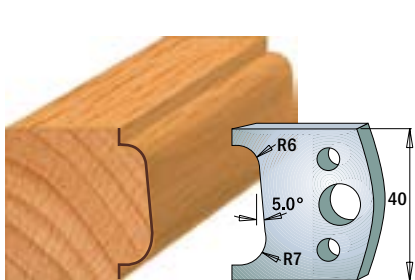

690.002 ORDER NO کد سفارش

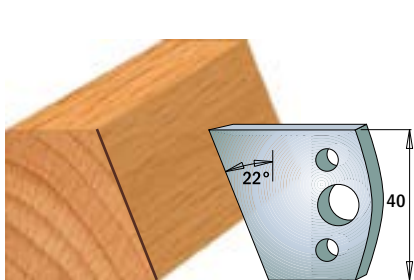

690.001 ORDER NO کد سفارش

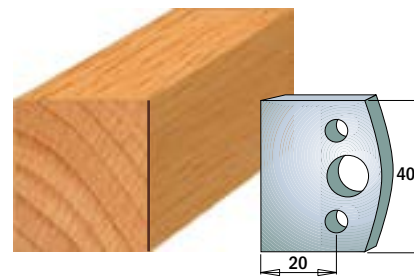

690.000 ORDER NO کد سفارش

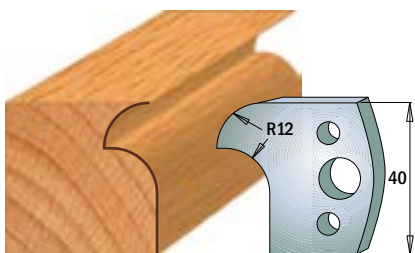

690.005 ORDER NO کد سفارش

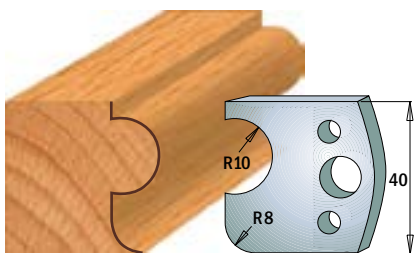

690.004 ORDER NO کد سفارش

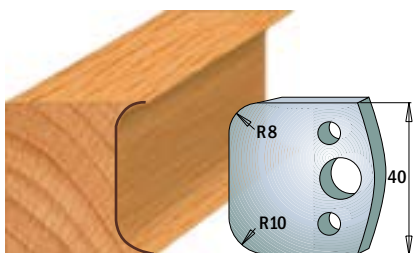

690.003 ORDER NO کد سفارش

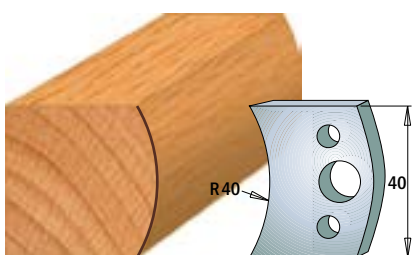

690.008 ORDER NO کد سفارش

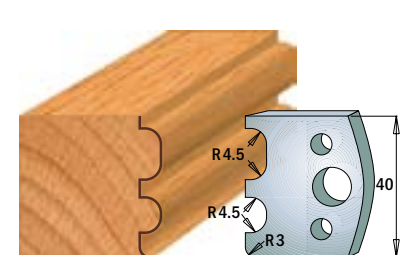

690.007 ORDER NO کد سفارش

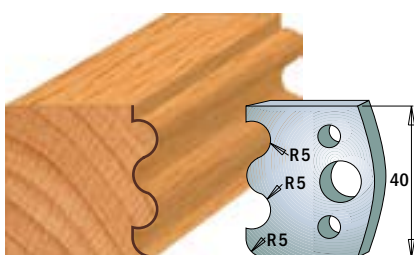

690.006 ORDER NO کد سفارش

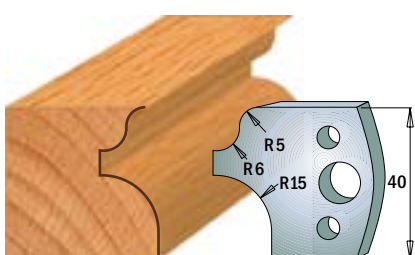

690.011 ORDER NO کد سفارش

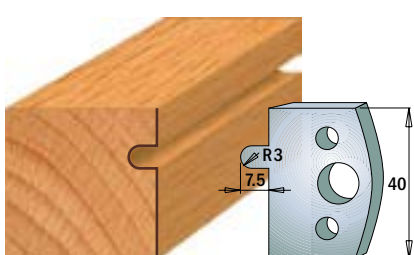

690.010 ORDER NO کد سفارش

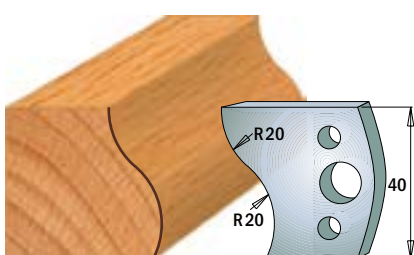

690.009 ORDER NO کد سفارش

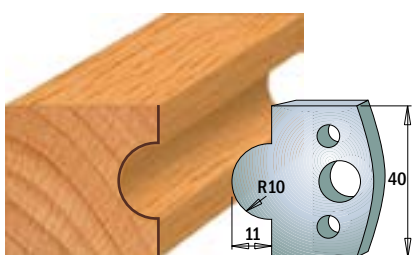

690.014 ORDER NO کد سفارش

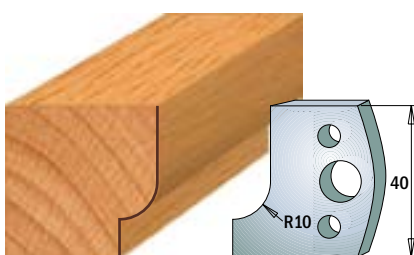

690.013 ORDER NO کد سفارش

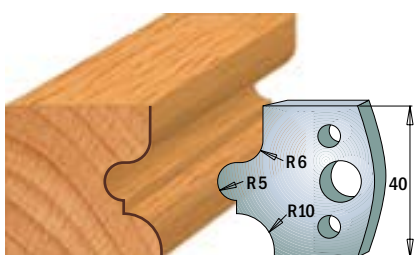

690.012 ORDER NO کد سفارش

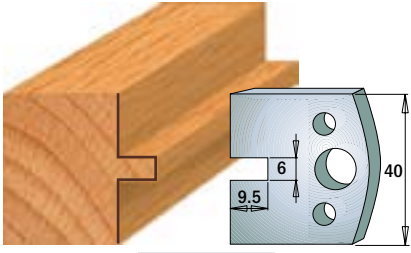

690.017 ORDER NO کد سفارش

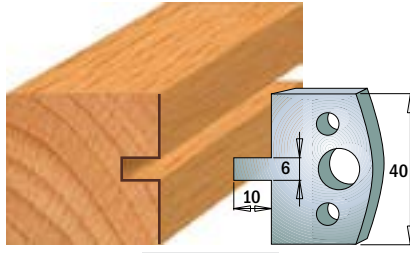

690.016 ORDER NO کد سفارش

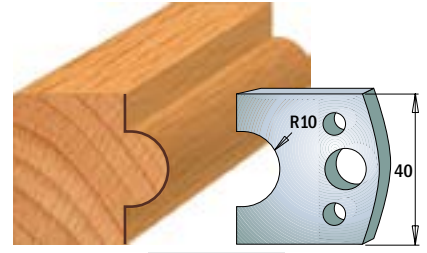

690.015 ORDER NO کد سفارش

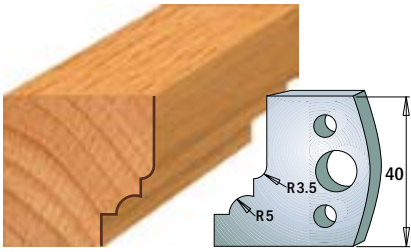

690.020 ORDER NO کد سفارش

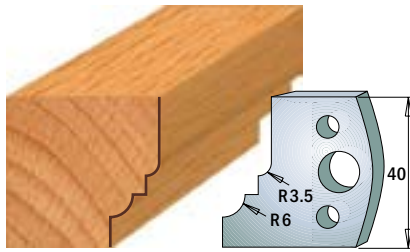

690.019 ORDER NO کد سفارش

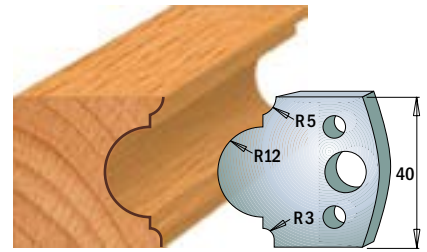

690.018 ORDER NO کد سفارش

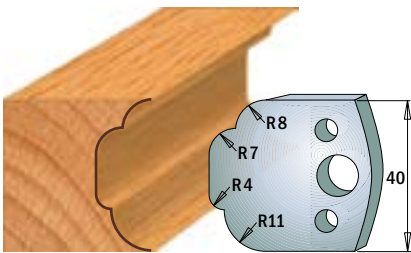

690.023 ORDER NO کد سفارش

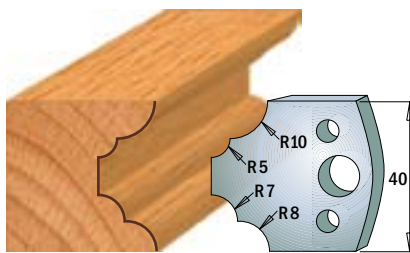

690.022 ORDER NO کد سفارش

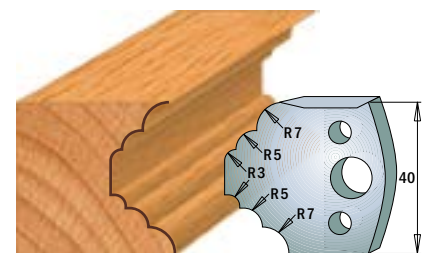

690.021 ORDER NO کد سفارش

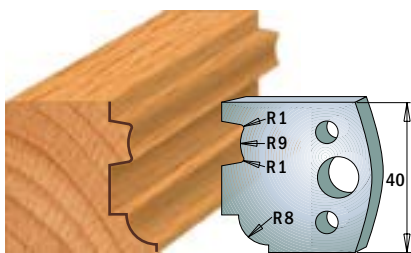

690.026 ORDER NO کد سفارش

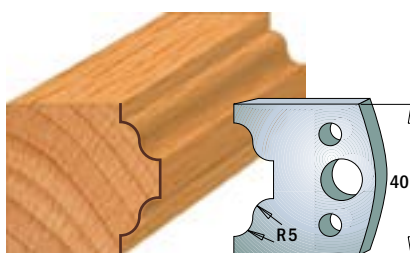

690.025 ORDER NO کد سفارش

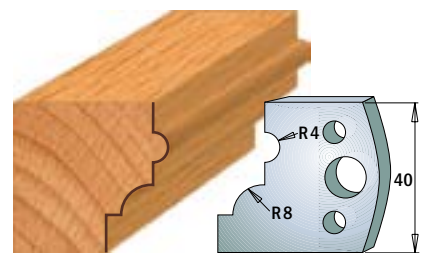

690.024 ORDER NO کد سفارش

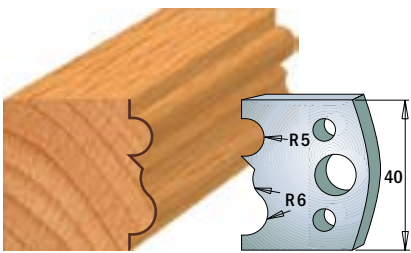

690.029 ORDER NO کد سفارش

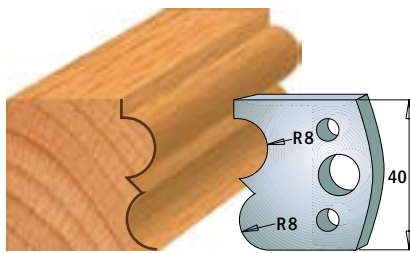

690.028 ORDER NO کد سفارش

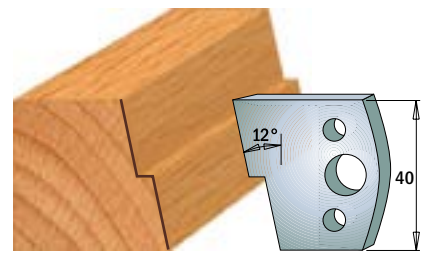

690.027 ORDER NO کد سفارش

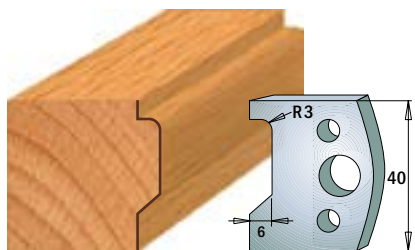

690.032 ORDER NO کد سفارش

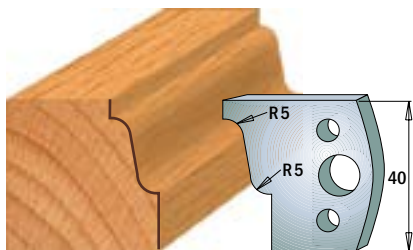

690.031 ORDER NO کد سفارش

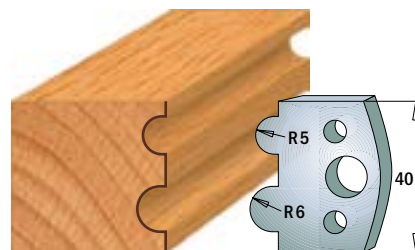

690.030 ORDER NO کد سفارش

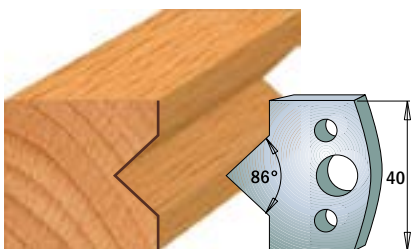

690.035 ORDER NO کد سفارش

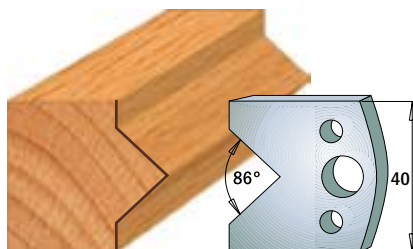

690.034 ORDER NO کد سفارش

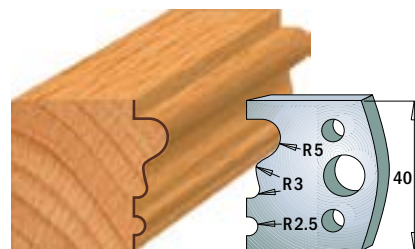

690.033 ORDER NO کد سفارش

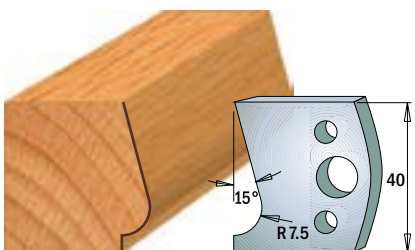

690.038 ORDER NO کد سفارش

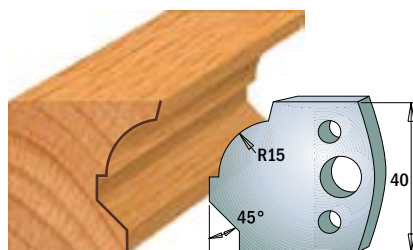

690.037 ORDER NO کد سفارش

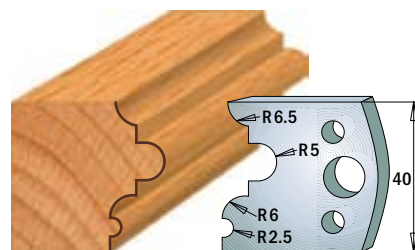

690.036 ORDER NO کد سفارش

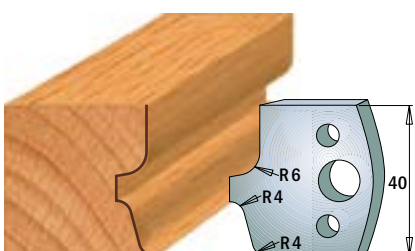

690.041 ORDER NO کد سفارش

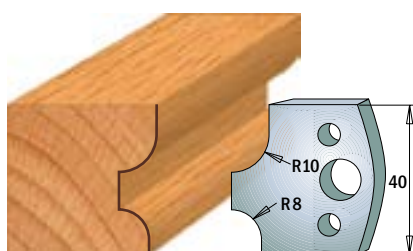

690.040 ORDER NO کد سفارش

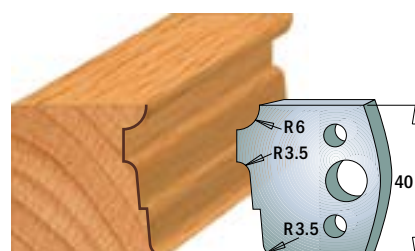

690.039 ORDER NO کد سفارش

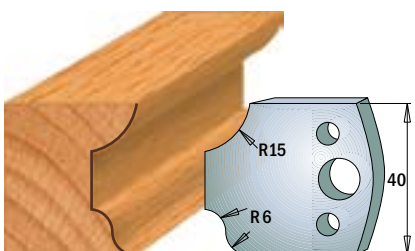

690.044 ORDER NO کد سفارش

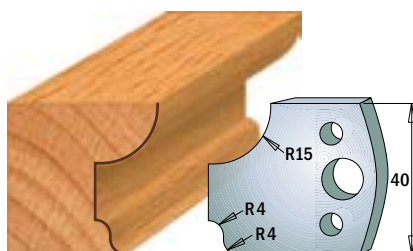

690.043 ORDER NO کد سفارش

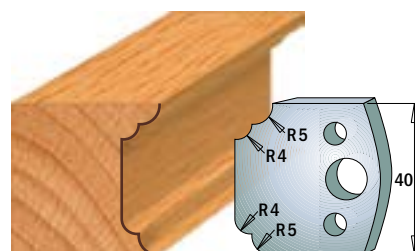

690.042 ORDER NO کد سفارش



### 3. Profile Knives and Limiters

SP

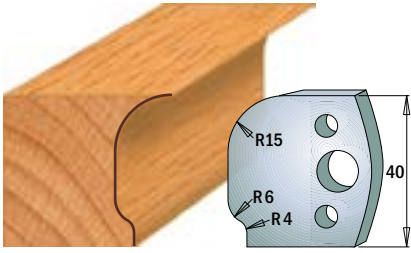

690.047 ORDER NO کد سفارش

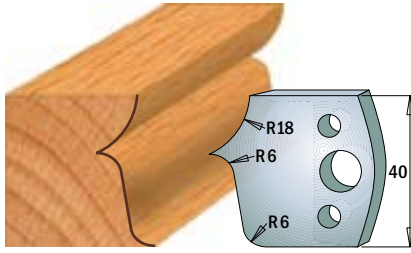

690.046 ORDER NO کد سفارش

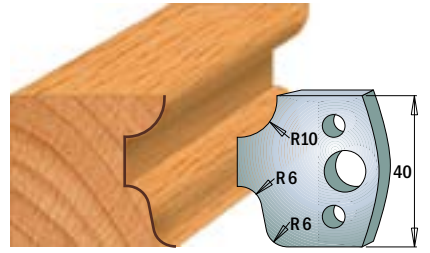

690.045 ORDER NO کد سفارش

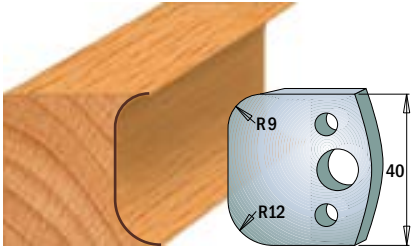

690.050 ORDER NO کد سفارش

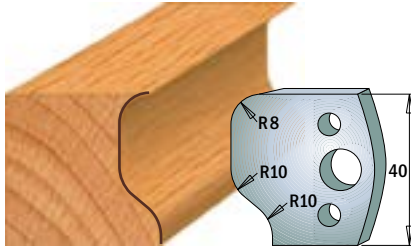

690.049 ORDER NO کد سفارش

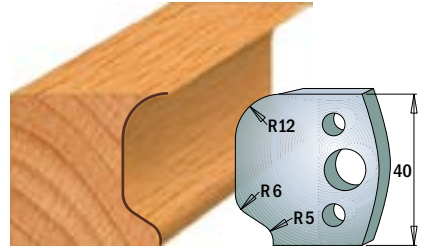

690.048 ORDER NO کد سفارش

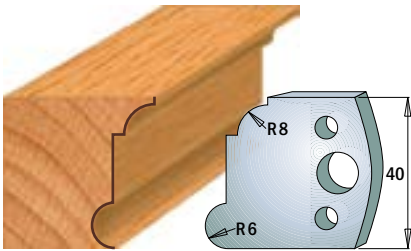

690.053 ORDER NO کد سفارش

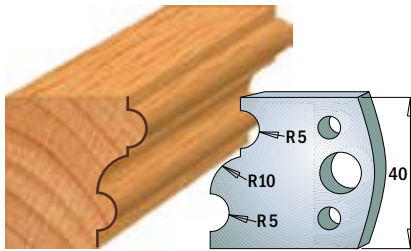

690.052 ORDER NO کد سفارش

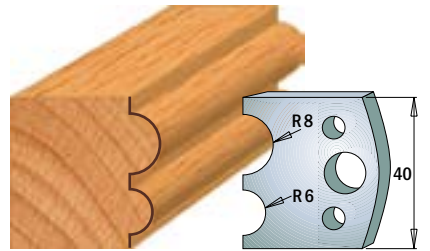

690.051 ORDER NO کد سفارش

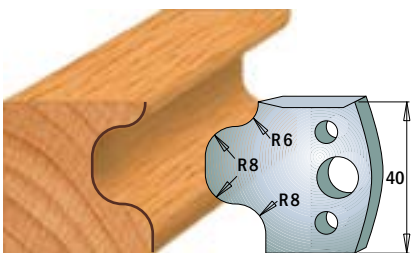

690.056 ORDER NO کد سفارش

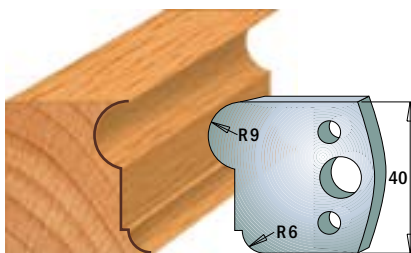

690.055 ORDER NO کد سفارش

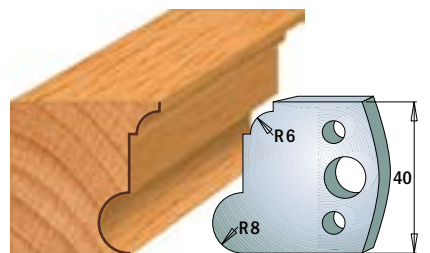

690.054 ORDER NO کد سفارش

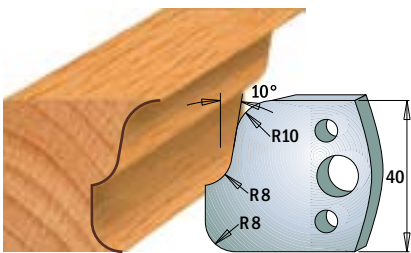

690.059 ORDER NO کد سفارش

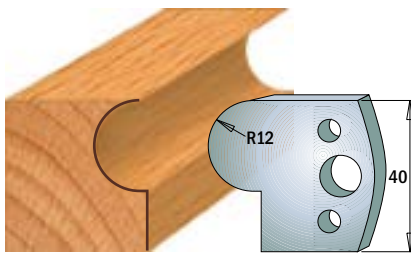

690.058 ORDER NO کد سفارش

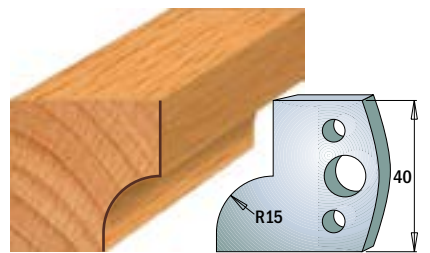

690.057 ORDER NO کد سفارش

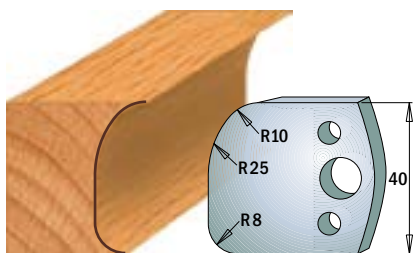

690.062 ORDER NO کد سفارش

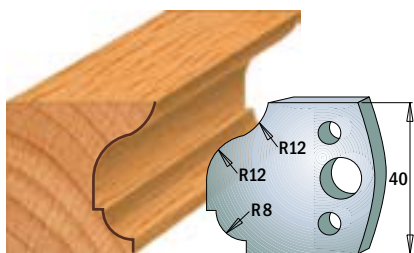

690.061 ORDER NO کد سفارش

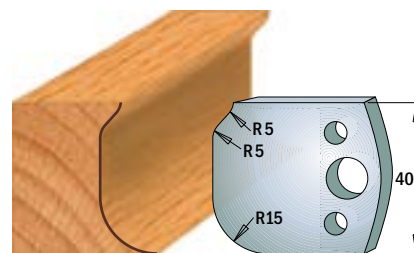

690.060 ORDER NO کد سفارش

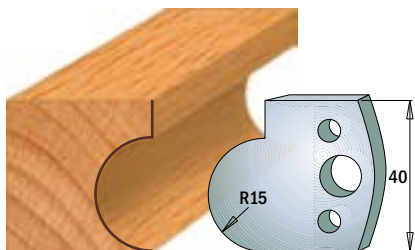

690.065 ORDER NO کد سفارش

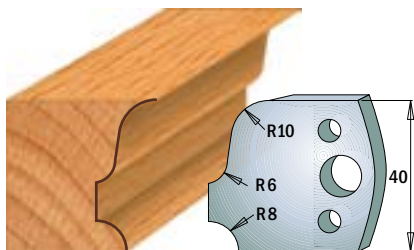

690.064 ORDER NO کد سفارش

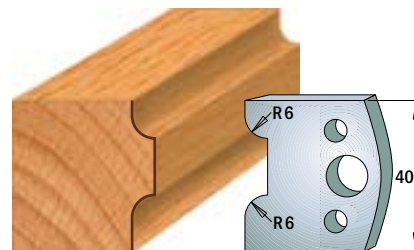

690.063 ORDER NO کد سفارش

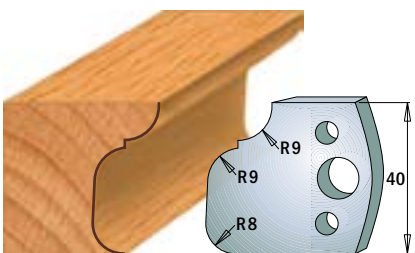

690.068 ORDER NO کد سفارش

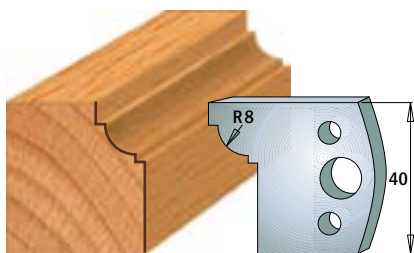

690.067 ORDER NO کد سفارش

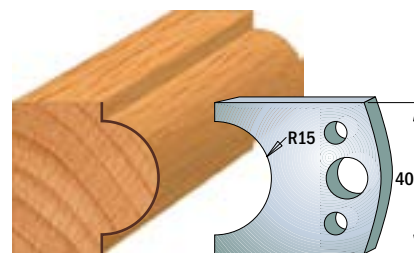

690.066 ORDER NO کد سفارش

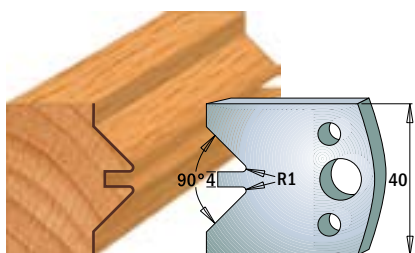

690.071 ORDER NO کد سفارش

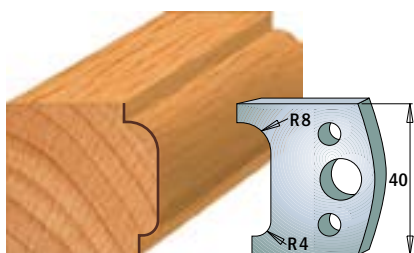

690.070 ORDER NO کد سفارش

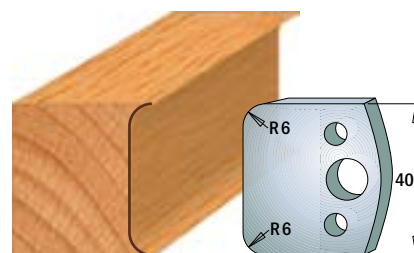

690.069 ORDER NO کد سفارش

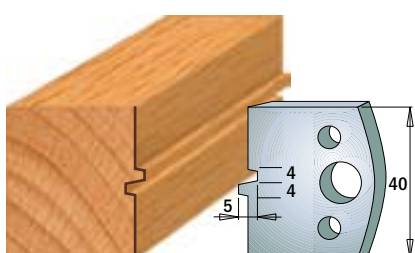

690.074 ORDER NO کد سفارش

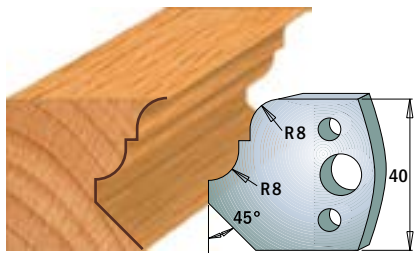

690.073 ORDER NO کد سفارش

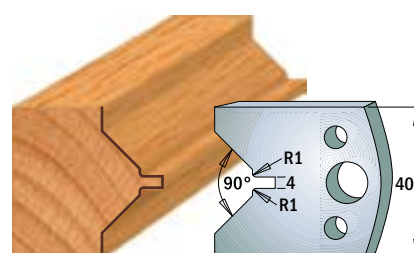

690.072 ORDER NO کد سفارش



### 3. Profile Knives and Limiters

SP

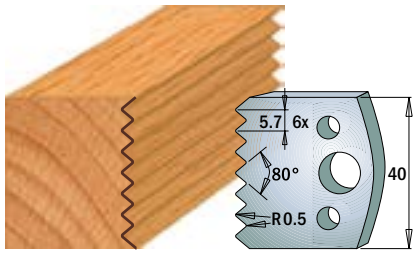

690.077 ORDER NO کد سفارش

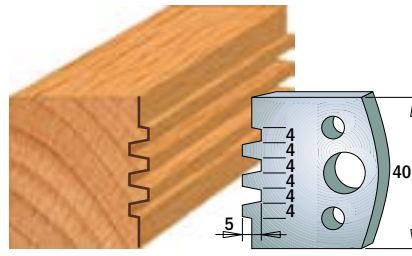

690.076 ORDER NO کد سفارش

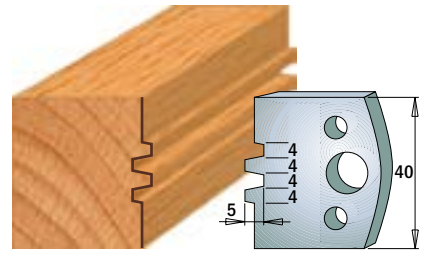

690.075 ORDER NO کد سفارش

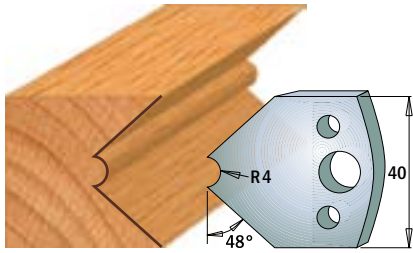

690.080 ORDER NO کد سفارش

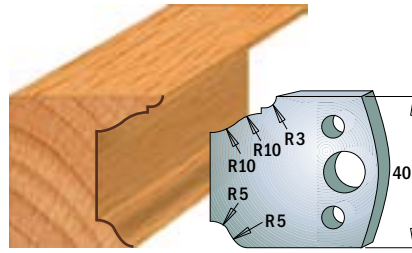

690.079 ORDER NO کد سفارش

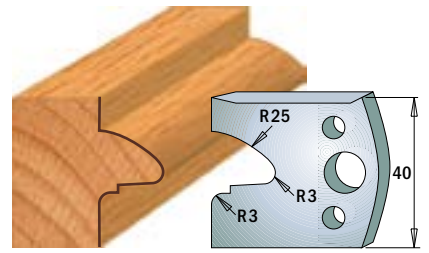

690.078 ORDER NO کد سفارش

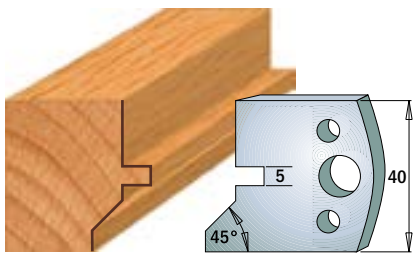

690.083 ORDER NO کد سفارش

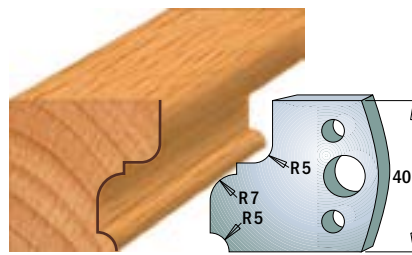

690.082 ORDER NO کد سفارش

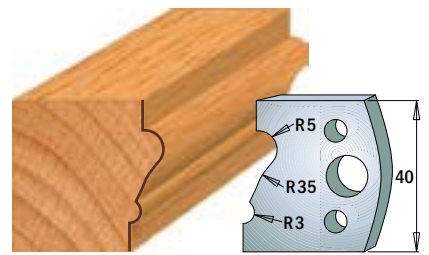

690.081 ORDER NO کد سفارش

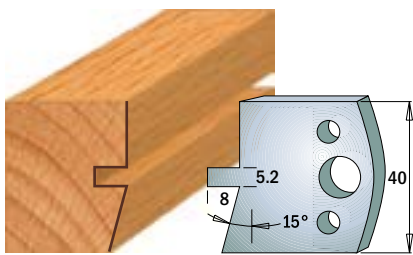

690.086 ORDER NO کد سفارش

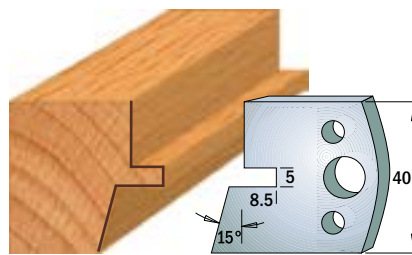

690.085 ORDER NO کد سفارش

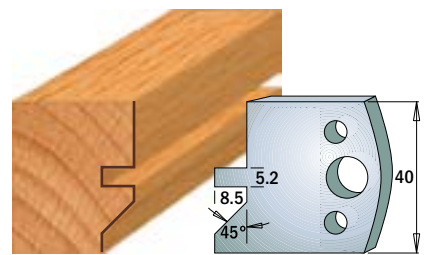

690.084 ORDER NO کد سفارش

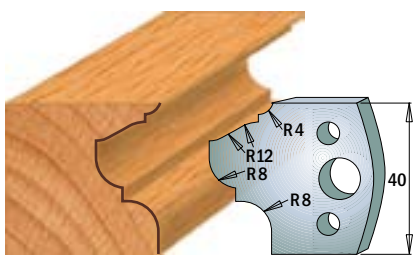

690.089 ORDER NO کد سفارش

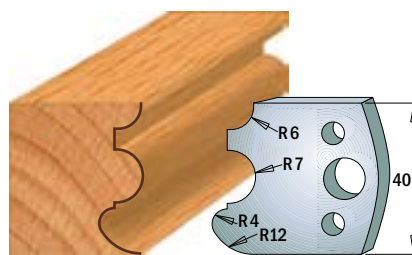

690.088 ORDER NO کد سفارش

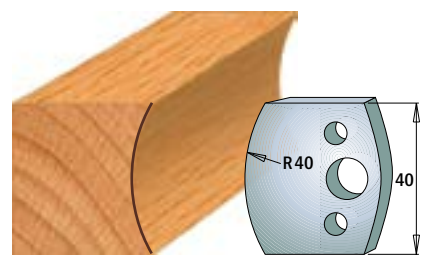

690.087 ORDER NO کد سفارش



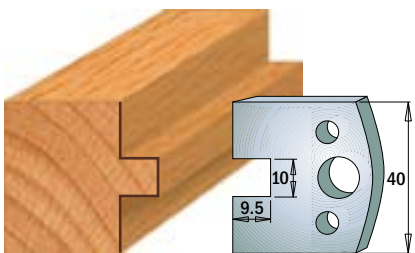

690.092 ORDER NO کد سفارش

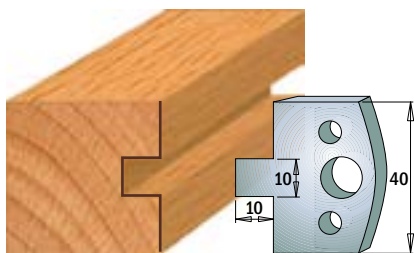

690.091 ORDER NO کد سفارش

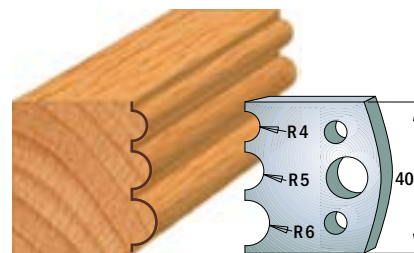

690.090 ORDER NO کد سفارش

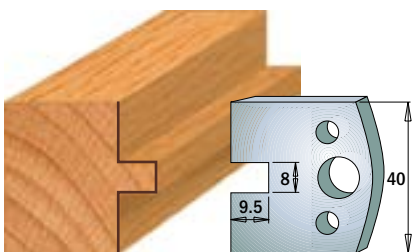

690.095 ORDER NO کد سفارش

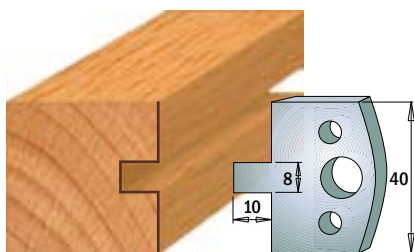

690.094 ORDER NO کد سفارش

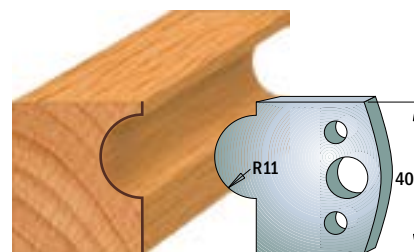

690.093 ORDER NO کد سفارش

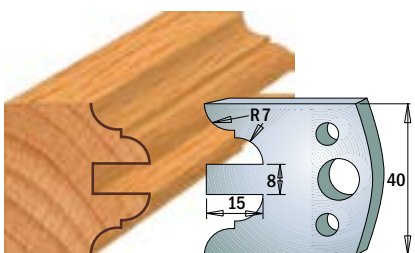

690.098 ORDER NO کد سفارش

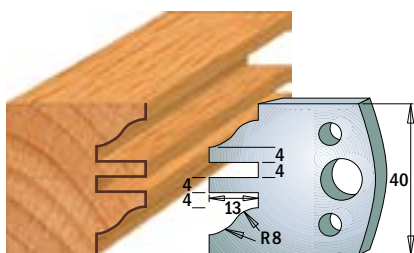

690.097 ORDER NO کد سفارش

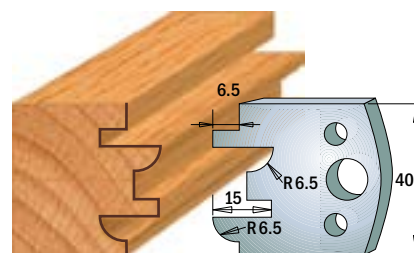

690.096 ORDER NO کد سفارش

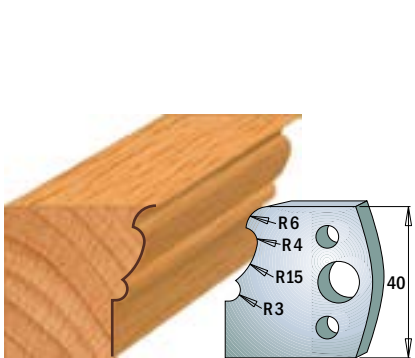

690.101 ORDER NO کد سفارش

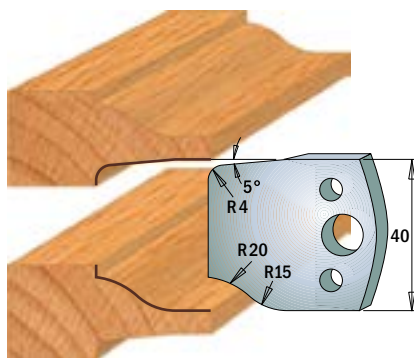

690.100 ORDER NO کد سفارش

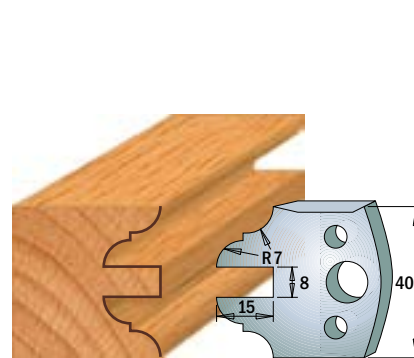

690.099 ORDER NO کد سفارش

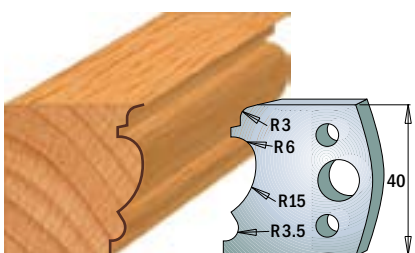

690.104 ORDER NO کد سفارش

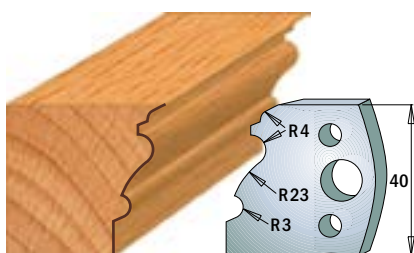

690.103 ORDER NO کد سفارش

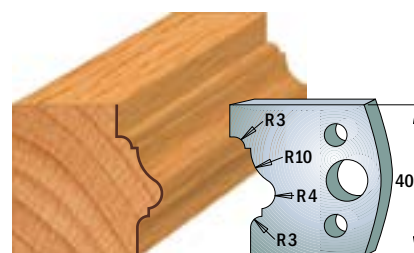

690.102 ORDER NO کد سفارش

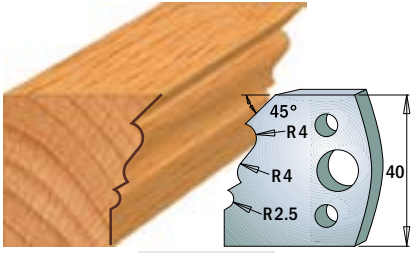

690.107 ORDER NO کد سفارش

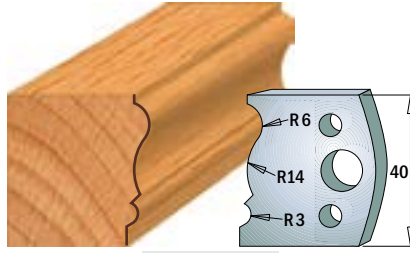

690.106 ORDER NO کد سفارش

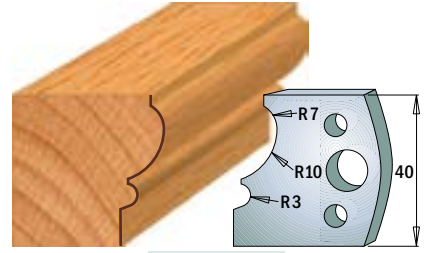

690.105 ORDER NO کد سفارش

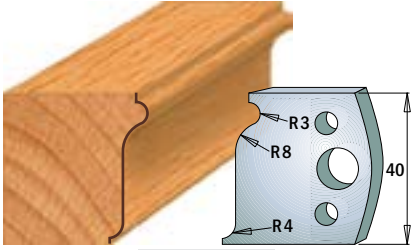

690.110 ORDER NO کد سفارش

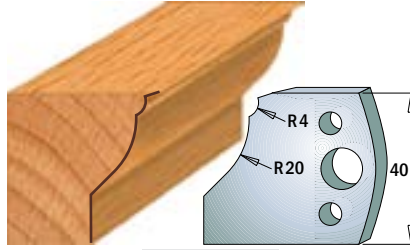

690.109 ORDER NO کد سفارش

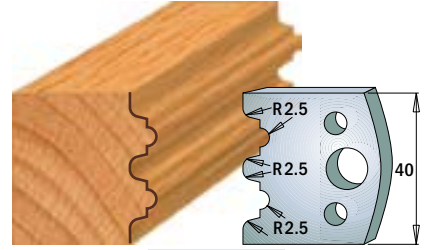

690.108 ORDER NO کد سفارش

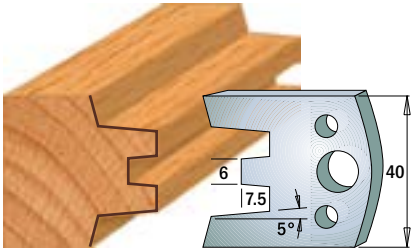

690.113 ORDER NO کد سفارش

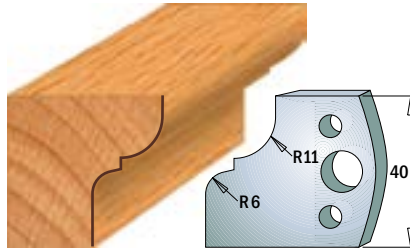

690.112 ORDER NO کد سفارش

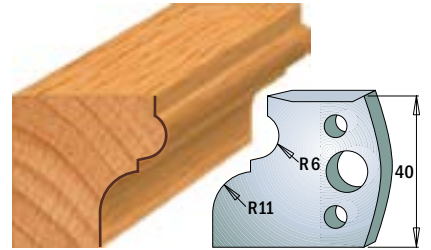

690.111 ORDER NO کد سفارش

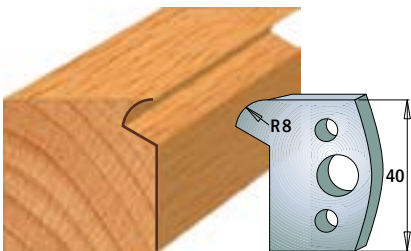

690.116 ORDER NO کد سفارش

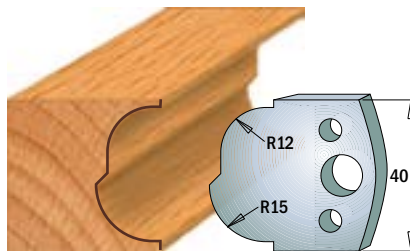

690.115 ORDER NO کد سفارش

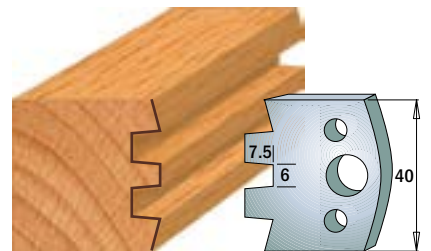

690.114 ORDER NO کد سفارش

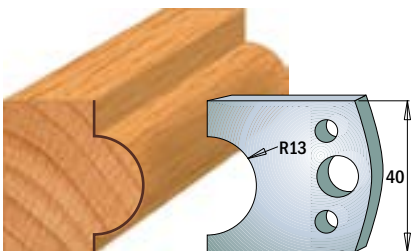

690.119 ORDER NO کد سفارش

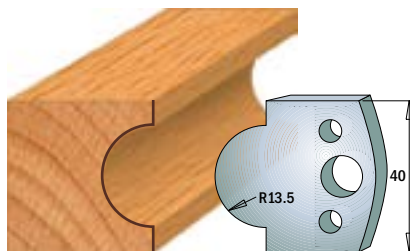

690.118 ORDER NO کد سفارش

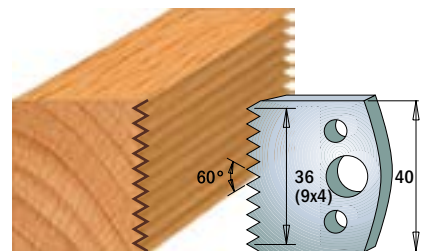

690.117 ORDER NO کد سفارش

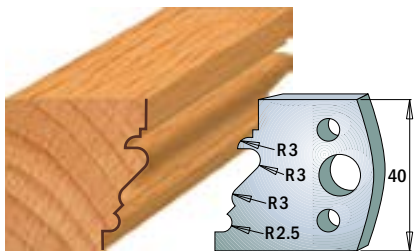

690.122 ORDER NO کد سفارش

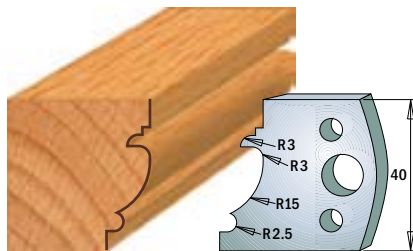

690.121 ORDER NO کد سفارش

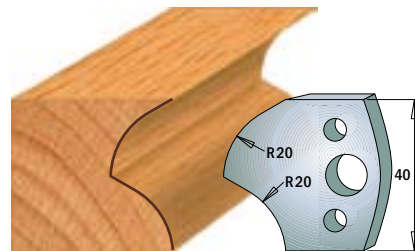

690.120 ORDER NO کد سفارش

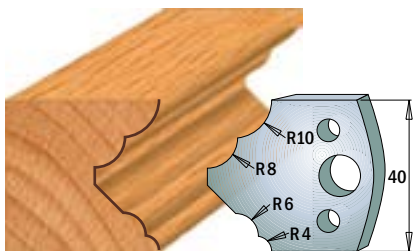

690.125 ORDER NO کد سفارش

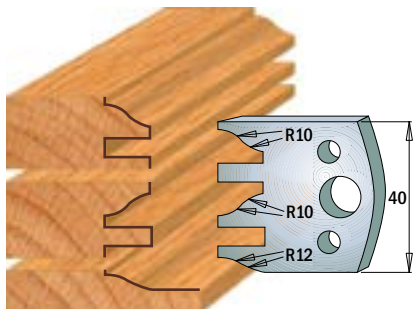

690.124 ORDER NO کد سفارش

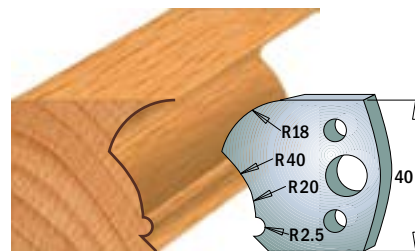

690.123 ORDER NO کد سفارش

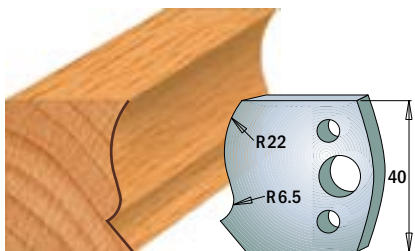

690.128 ORDER NO کد سفارش

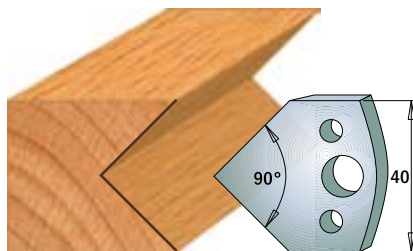

690.127 ORDER NO کد سفارش

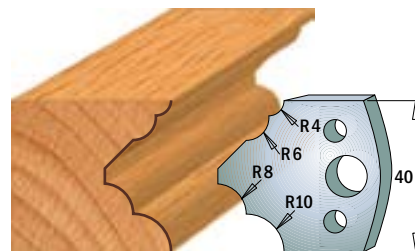

690.126 ORDER NO کد سفارش

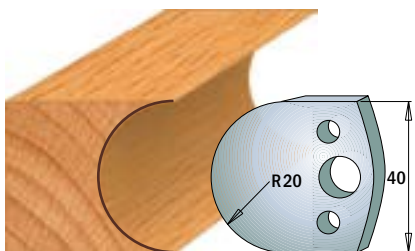

690.131 ORDER NO کد سفارش

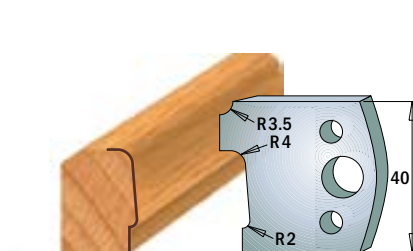

690.130 ORDER NO کد سفارش

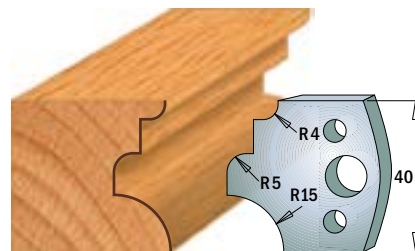

690.129 ORDER NO کد سفارش

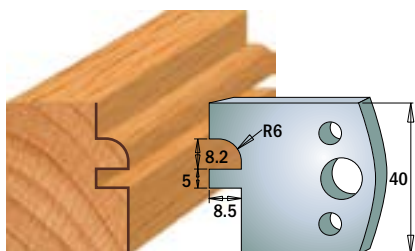

690.134 ORDER NO کد سفارش

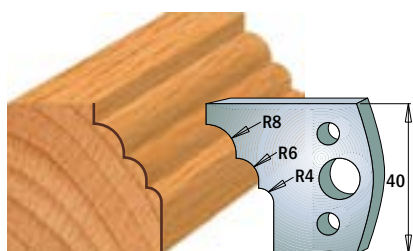

690.133 ORDER NO کد سفارش

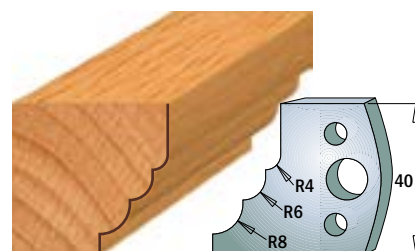

690.132 ORDER NO کد سفارش

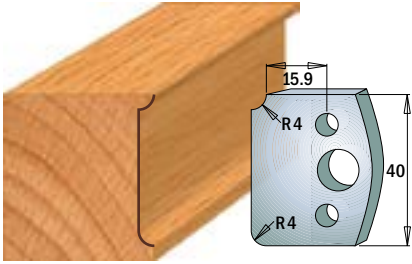

690.171 ORDER NO کد سفارش

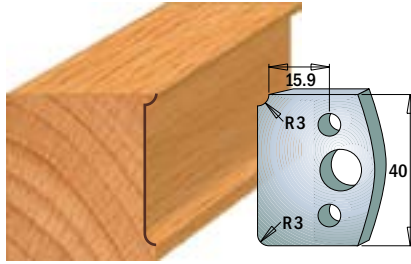

690.170 ORDER NO کد سفارش

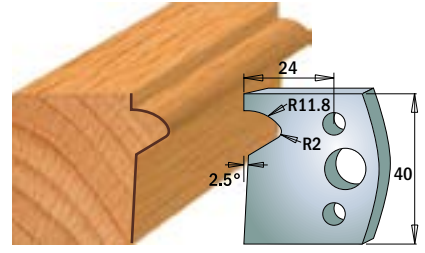

690.135 ORDER NO کد سفارش

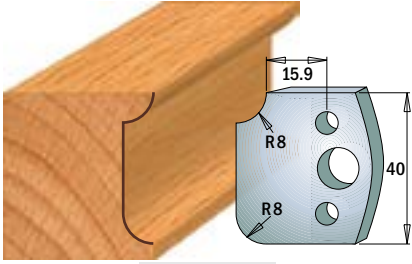

690.174 ORDER NO کد سفارش

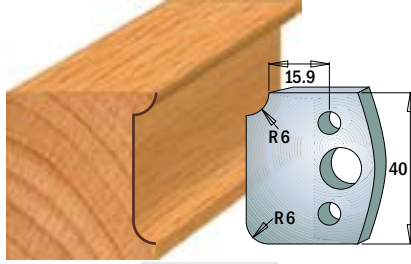

690.173 ORDER NO کد سفارش

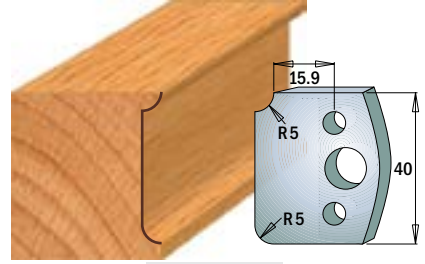

690.172 ORDER NO کد سفارش

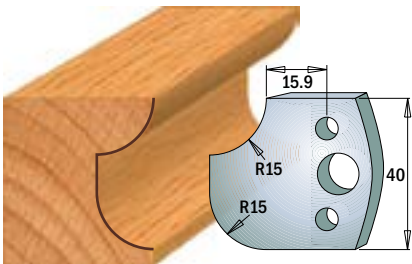

690.177 ORDER NO کد سفارش

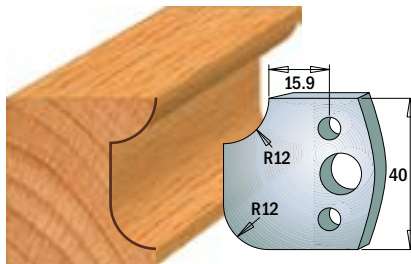

690.176 ORDER NO کد سفارش

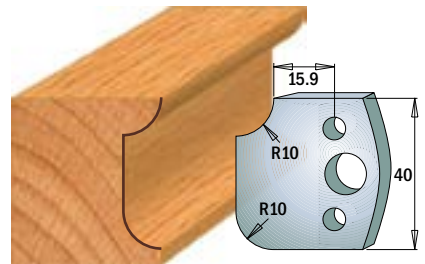

690.175 ORDER NO کد سفارش

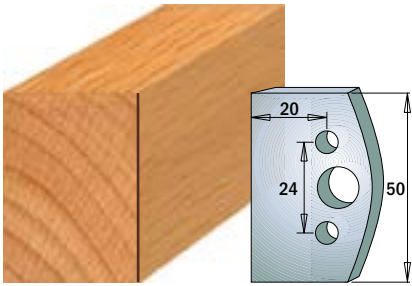

690.500 ORDER NO کد سفارش

کارگیر  
۵۰  
میلی متری

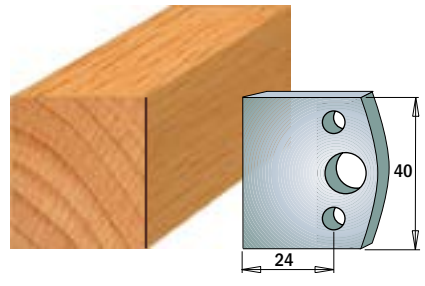

690.192 ORDER NO کد سفارش

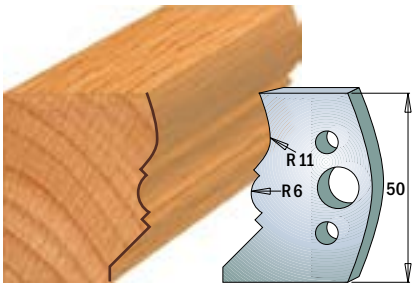

690.503 ORDER NO کد سفارش

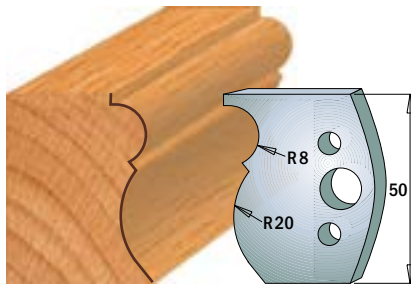

690.502 ORDER NO کد سفارش

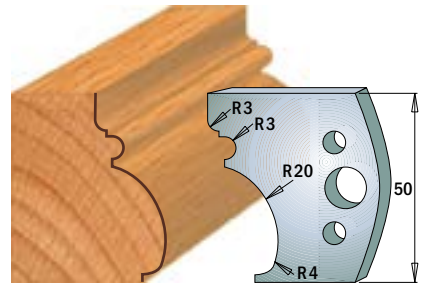

690.501 ORDER NO کد سفارش

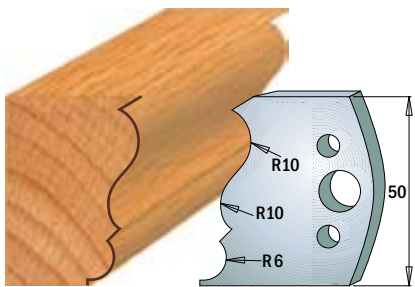

690.506 ORDER NO کد سفارش

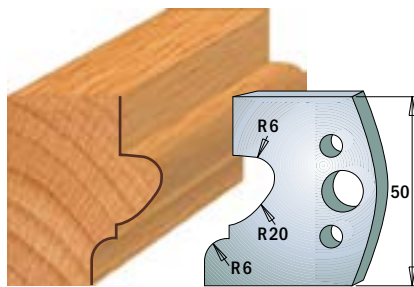

690.505 ORDER NO کد سفارش

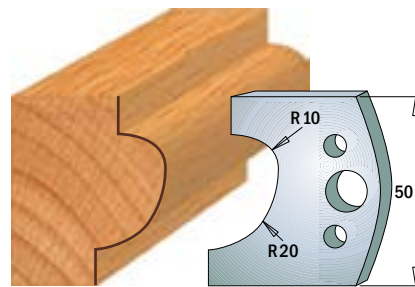

690.504 ORDER NO کد سفارش

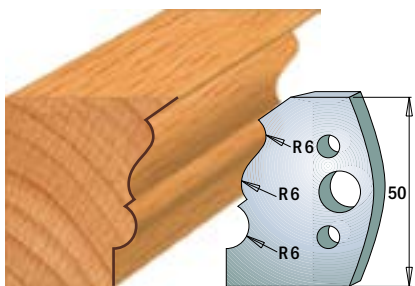

690.509 ORDER NO کد سفارش

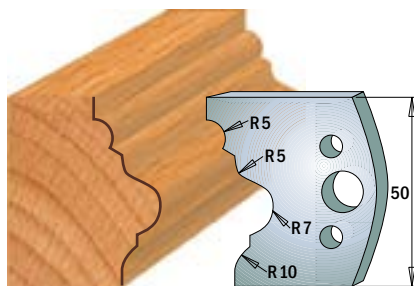

690.508 ORDER NO کد سفارش

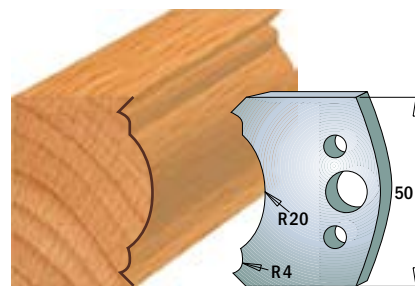

690.507 ORDER NO کد سفارش

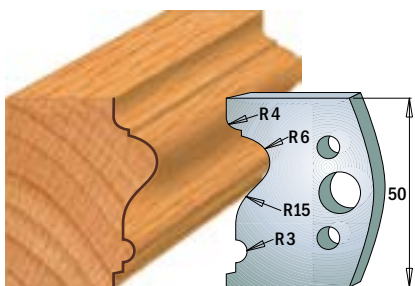

690.512 ORDER NO کد سفارش

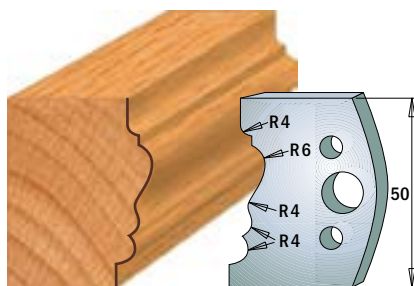

690.511 ORDER NO کد سفارش

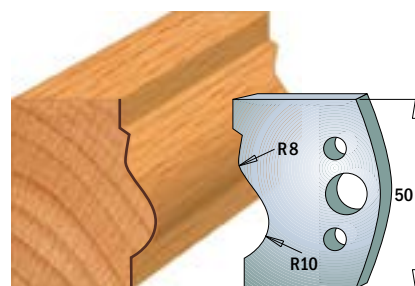

690.510 ORDER NO کد سفارش

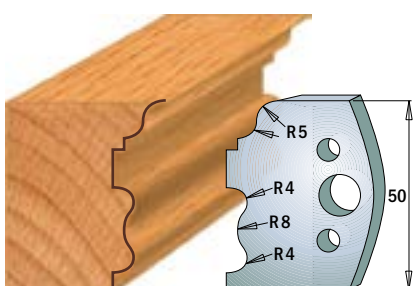

690.515 ORDER NO کد سفارش

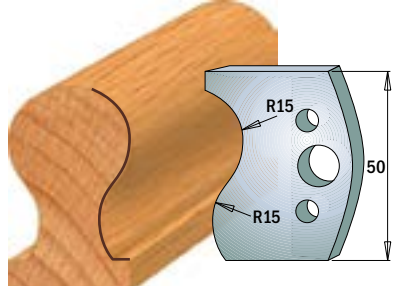

690.514 ORDER NO کد سفارش

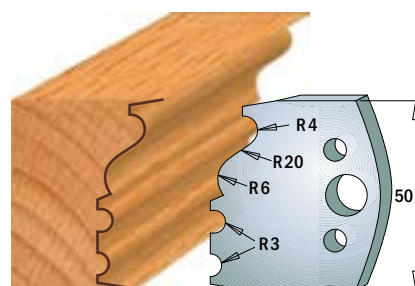

690.513 ORDER NO کد سفارش

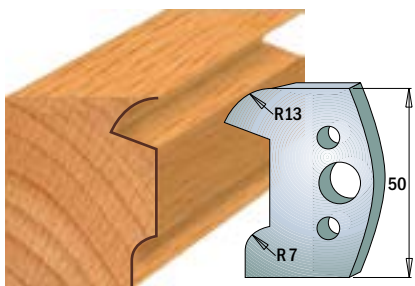

690.518 ORDER NO کد سفارش

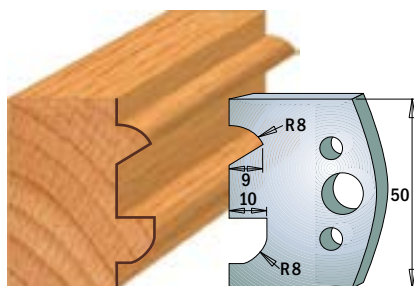

690.517 ORDER NO کد سفارش

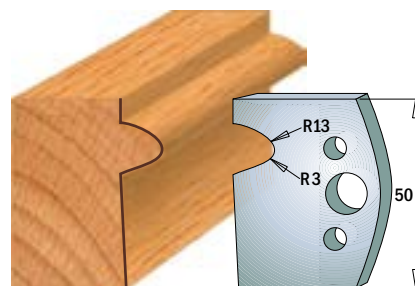

690.516 ORDER NO کد سفارش



### 3. Profile Knives and Limiters

SP

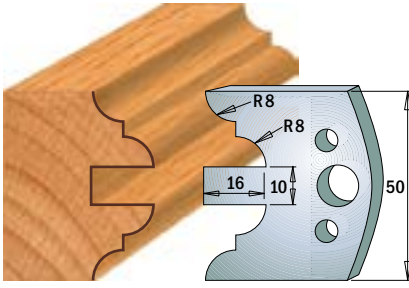

690.522 ORDER NO کد سفارش

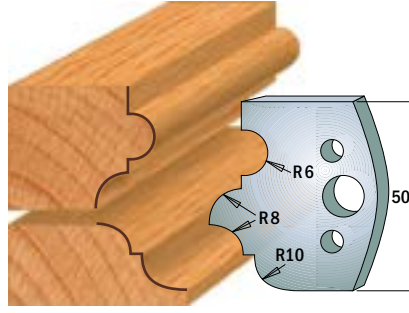

690.520 ORDER NO کد سفارش

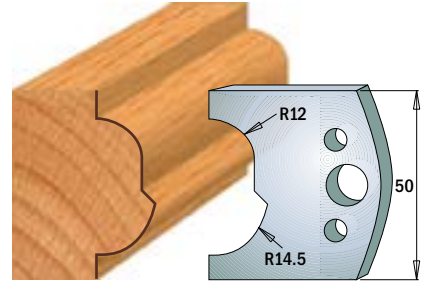

690.519 ORDER NO کد سفارش

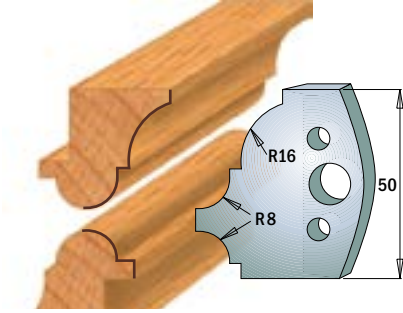

690.541 ORDER NO کد سفارش

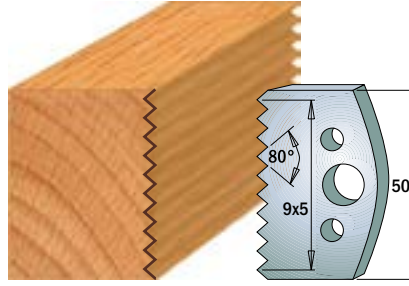

690.524 ORDER NO کد سفارش

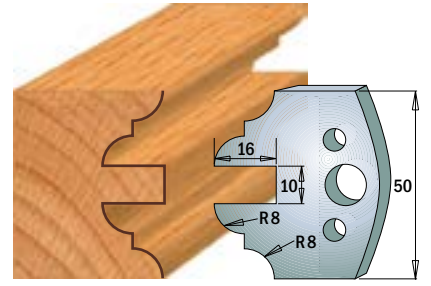

690.523 ORDER NO کد سفارش

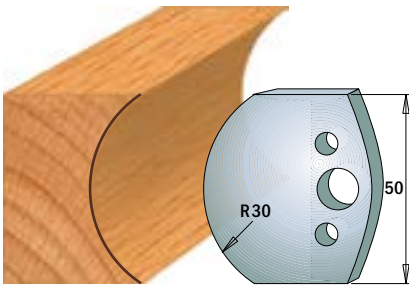

690.544 ORDER NO کد سفارش

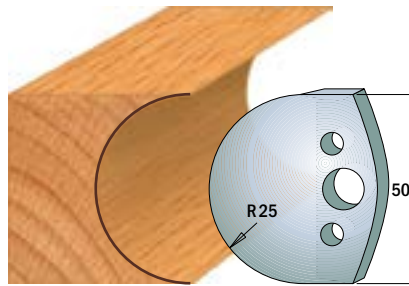

690.543 ORDER NO کد سفارش

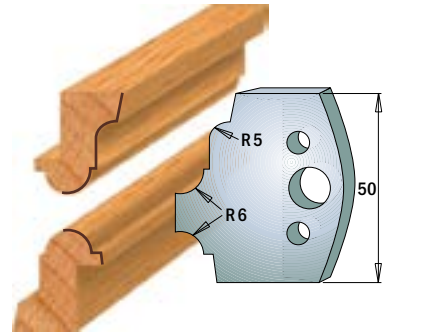

690.542 ORDER NO کد سفارش

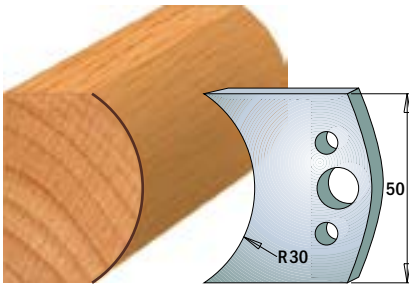

690.547 ORDER NO کد سفارش

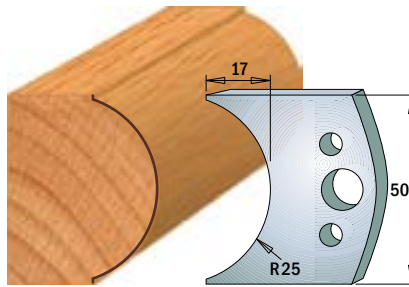

690.546 ORDER NO کد سفارش

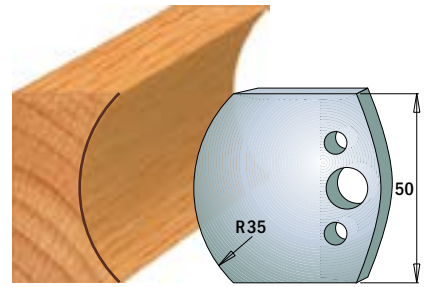

690.545 ORDER NO کد سفارش

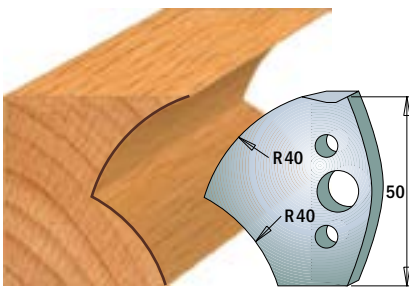

690.550 ORDER NO کد سفارش

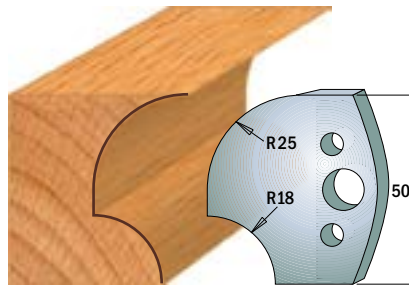

690.549 ORDER NO کد سفارش

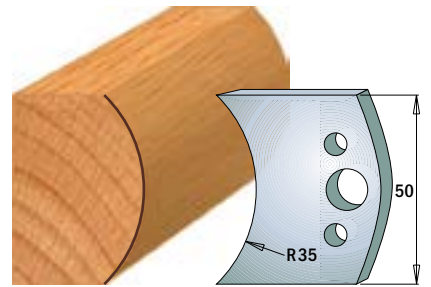

690.548 ORDER NO کد سفارش

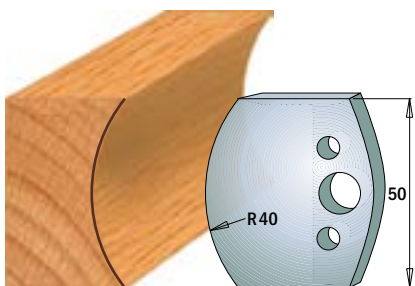

690.553 ORDER NO کد سفارش

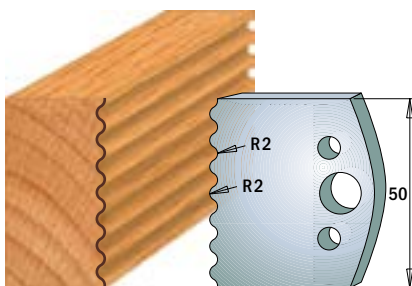

690.552 ORDER NO کد سفارش

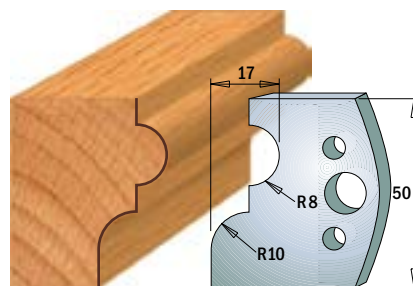

690.551 ORDER NO کد سفارش

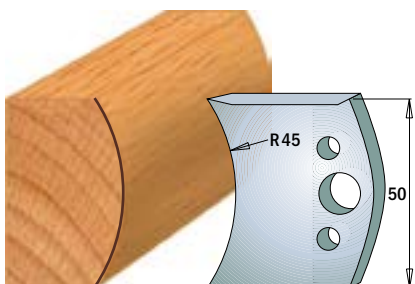

690.556 ORDER NO کد سفارش

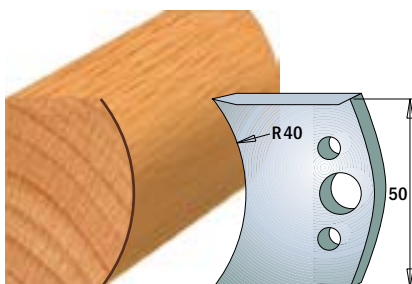

690.555 ORDER NO کد سفارش

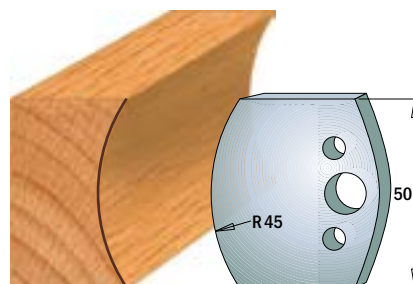

690.554 ORDER NO کد سفارش



690.559 ORDER NO کد سفارش

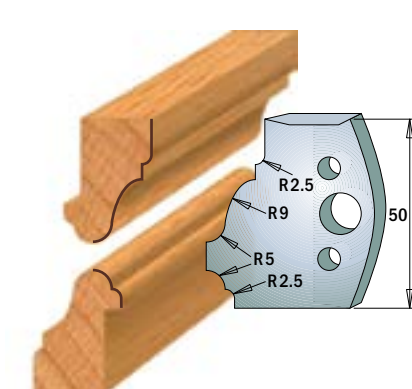

690.558 ORDER NO کد سفارش

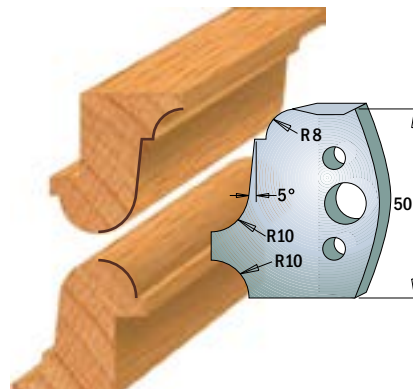

690.557 ORDER NO کد سفارش

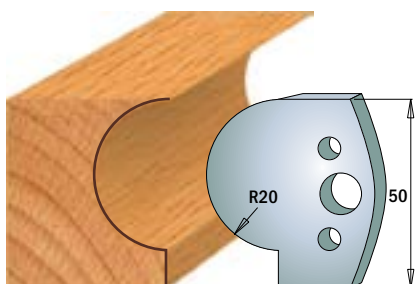

690.562 ORDER NO کد سفارش

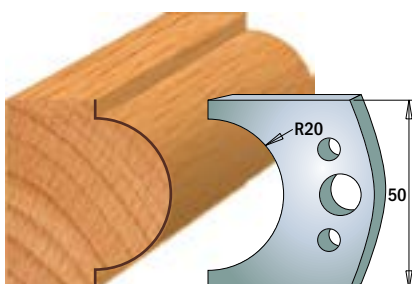

690.561 ORDER NO کد سفارش

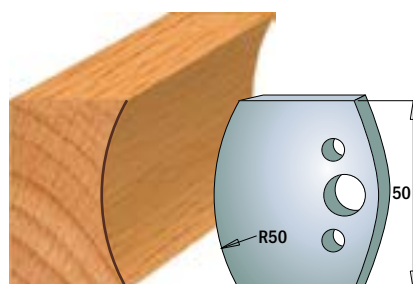

690.560 ORDER NO کد سفارش

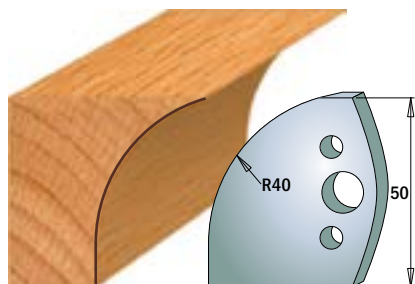

690.565 ORDER NO کد سفارش

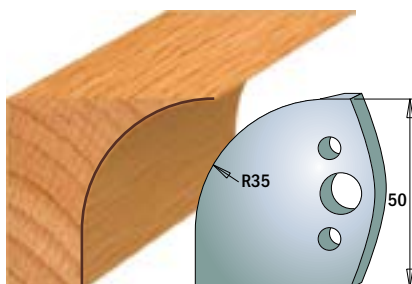

690.564 ORDER NO کد سفارش

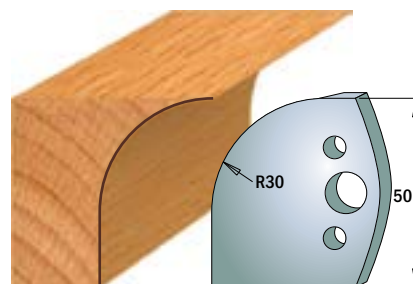

690.563 ORDER NO کد سفارش



### 3. Profile Knives and Limiters

SP

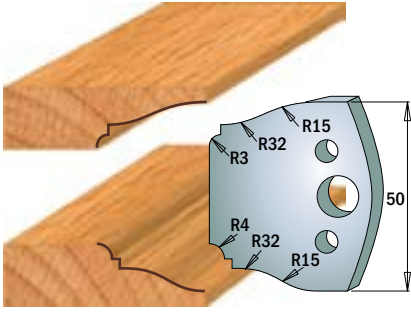

690.568 ORDER NO کد سفارش

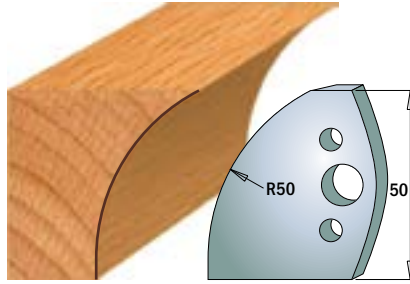

690.567 ORDER NO کد سفارش

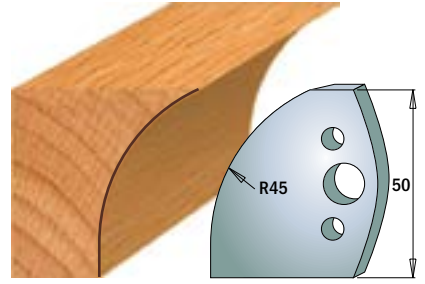

690.566 ORDER NO کد سفارش

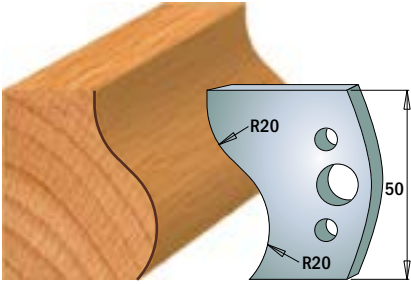

690.571 ORDER NO کد سفارش

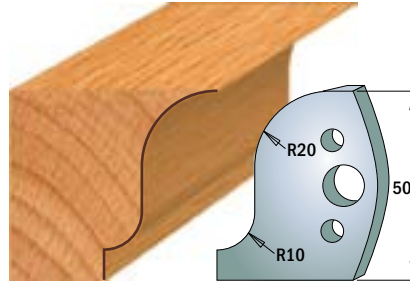

690.570 ORDER NO کد سفارش

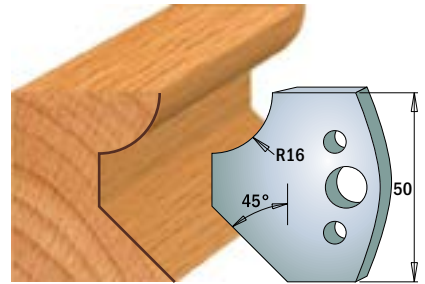

690.569 ORDER NO کد سفارش

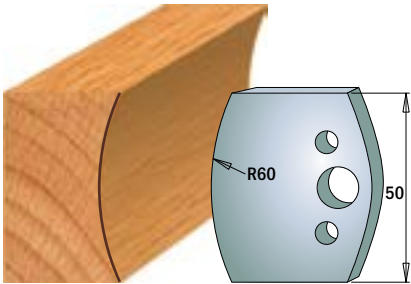

690.574 ORDER NO کد سفارش

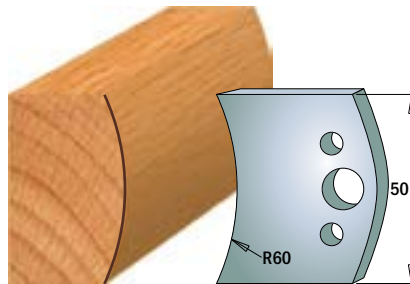

690.573 ORDER NO کد سفارش

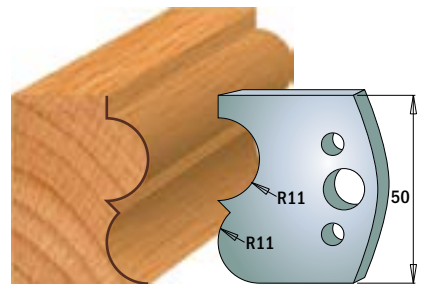

690.572 ORDER NO کد سفارش

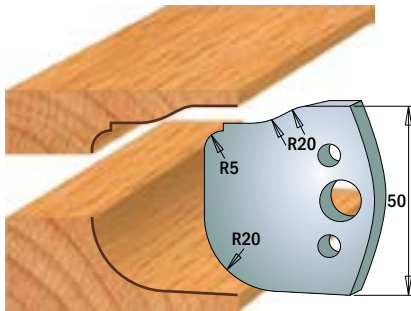

690.577 ORDER NO کد سفارش

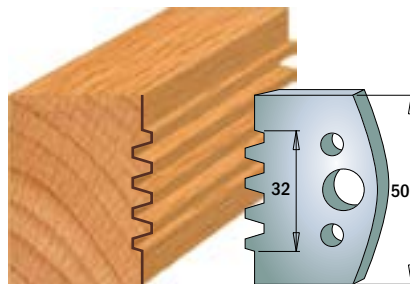

690.576 ORDER NO کد سفارش

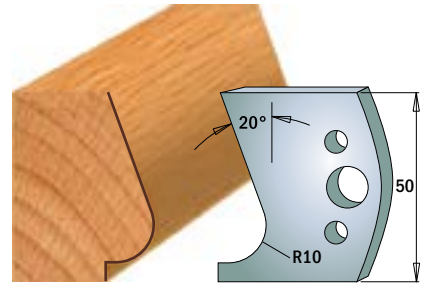

690.575 ORDER NO کد سفارش

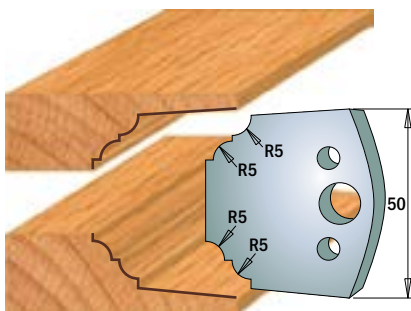

690.580 ORDER NO کد سفارش

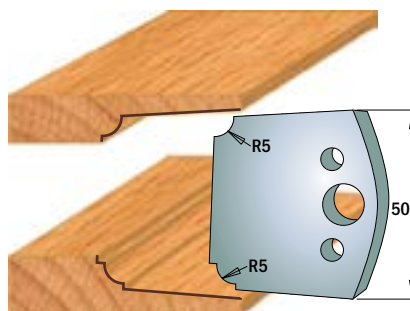

690.579 ORDER NO کد سفارش

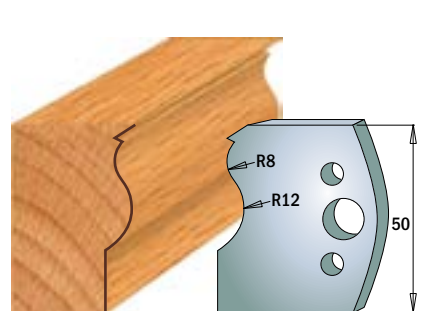

690.578 ORDER NO کد سفارش







#### 4. Industrial Dowel Drills

### 314

مته الیت نوک تیز (راه بَدَر)  
2 Flute Dowel Drills for Through Holes

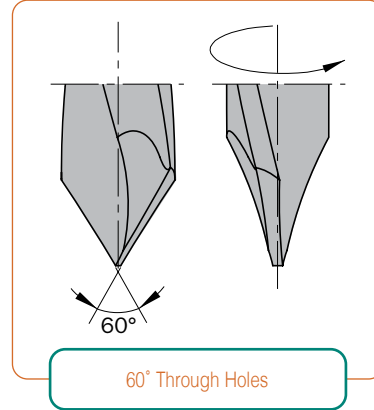
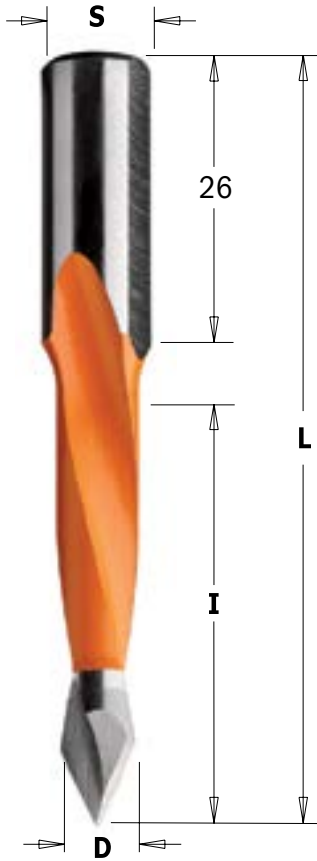

قطر	کارگیر	طول	شفت	کد سفارش راست گرد	کد سفارش چپ گرد
D mm	I mm	L mm	S mm	ORDER NO Right-hand rotation	ORDER NO Left-hand rotation
5	35	70	10x26	314.050.11	314.050.12
6	35	70	10x26	314.060.11	314.060.12
8	35	70	10x26	314.080.11	314.080.12

### 313

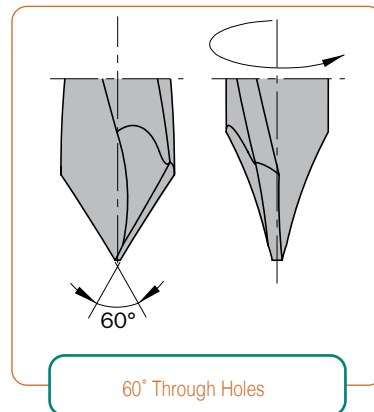
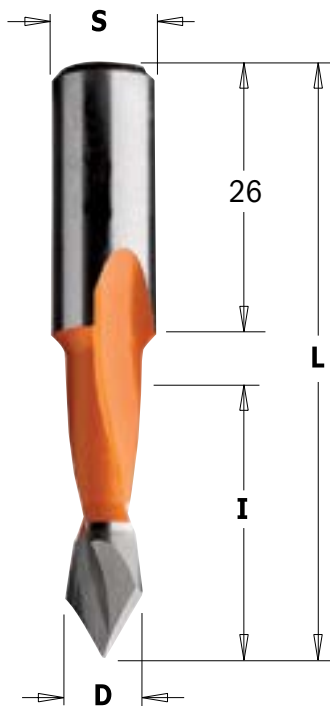

قطر	کارگیر	طول	شفت	کد سفارش راست گرد	کد سفارش چپ گرد	متعلقات	
D mm	I mm	L mm	S mm	ORDER NO	ORDER NO		
5	27	57,5	10x26	313.050.11	313.050.12	990.003.00	990.088.00
8	27	57,5	10x26	313.080.11	313.080.12	990.003.00	990.088.00
10	27	57,5	10x26	313.100.11	313.100.12	990.003.00	990.088.00

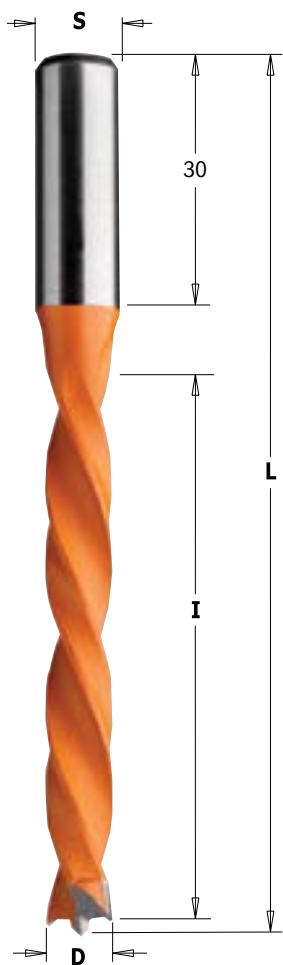

### 372

متها ایت سه نیش

4 Flute Dowel Drills

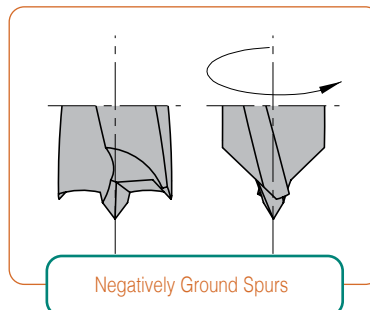

Negatively Ground Spurs

قطر	کارگیر	طول	شفت	کد سفارش راست گرد	کد سفارش چپ گرد	متعلقات	
D mm	I mm	L mm	S mm	ORDER NO	ORDER NO		
5	65	105	10x30	372.050.11	372.050.12	990.003.00	990.088.00
8	65	105	10x30	372.080.11	372.080.12	990.003.00	990.088.00
10	65	105	10x30	372.100.11	372.100.12	990.003.00	990.088.00
12	65	105	10x30	372.120.11	372.120.12	990.003.00	990.088.00

### 309

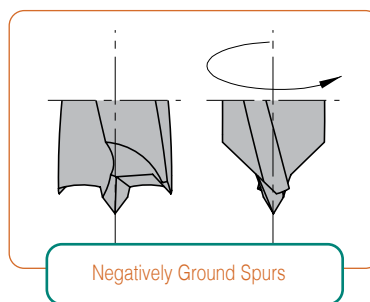
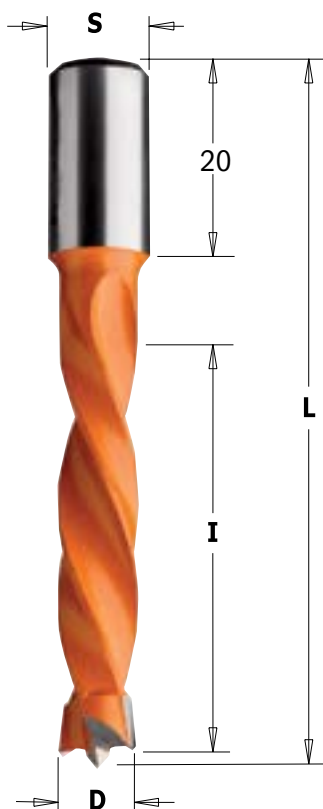

Negatively Ground Spurs

قطر	کارگیر	طول	شفت	کد سفارش راست گرد	کد سفارش چپ گرد	متعلقات	
D mm	I mm	L mm	S mm	ORDER NO	ORDER NO		
4	43	70	10x20	309.040.11	309.040.12	990.003.00	990.088.00
5	43	70	10x20	309.050.11	309.050.12	990.003.00	990.088.00
6	43	70	10x20	309.060.11	309.060.12	990.003.00	990.088.00
8	43	70	10x20	309.080.11	309.080.12	990.003.00	990.088.00
10	43	70	10x20	309.100.11	309.100.12	990.003.00	990.088.00
12	43	70	10x20	309.120.11	309.120.12	990.003.00	990.088.00
15	43	70	10x20	309.150.11	309.150.12	990.003.00	990.088.00



#### 4. Industrial Dowel Drills

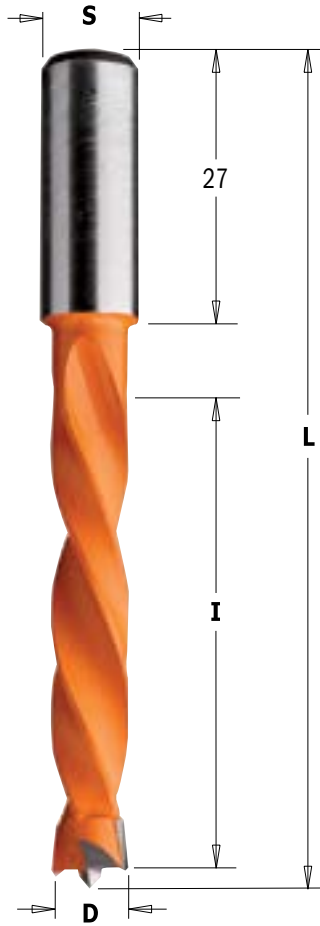

### 373

مته ایت سه نیش

4 Flute Dowel Drills

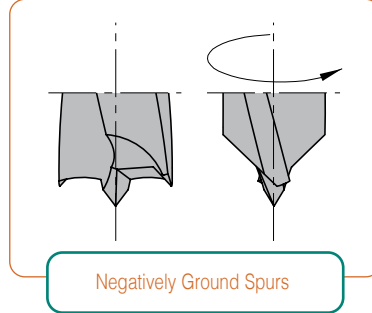

قطر	کارگیر	طول	شفت	کد سفارش راست گرد	کد سفارش چپ گرد	متعلقات	
D mm	I mm	L mm	S mm	ORDER NO	ORDER NO		
5	50	85	10x27	373.050.11	373.050.12	990.003.00	990.088.00
8	50	85	10x27	373.080.11	373.080.12	990.003.00	990.088.00
10	50	85	10x27	373.100.11	373.100.12	990.003.00	990.088.00
12	50	85	10x27	373.120.11	373.120.12	990.003.00	990.088.00

### 308

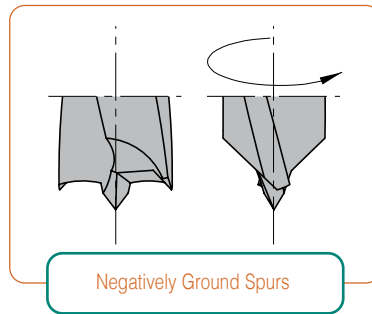
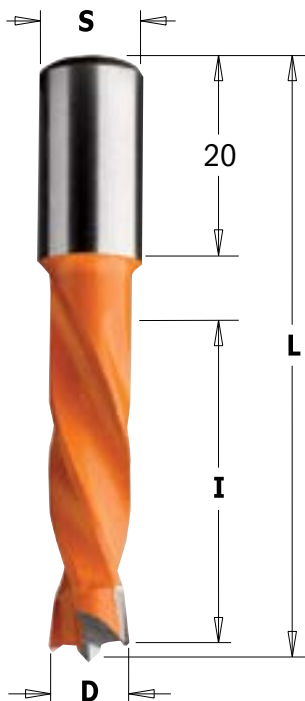

قطر	کارگیر	طول	شفت	کد سفارش راست گرد	کد سفارش چپ گرد	متعلقات	
D mm	I mm	L mm	S mm	ORDER NO	ORDER NO		
4	26	57,5	10x20	308.040.11	308.040.12	990.003.00	990.088.00
5	30	57,5	10x20	308.050.11	308.050.12	990.003.00	990.088.00
6	30	57,5	10x20	308.060.11	308.060.12	990.003.00	990.088.00
8	30	57,5	10x20	308.080.11	308.080.12	990.003.00	990.088.00
10	30	57,5	10x20	308.100.11	308.100.12	990.003.00	990.088.00
12	30	57,5	10x20	308.120.11	308.120.12	990.003.00	990.088.00
15	30	57,5	10x20	308.150.11	308.150.12	990.003.00	990.088.00



مته گازر

Hinge Boring Bits

317-370-369

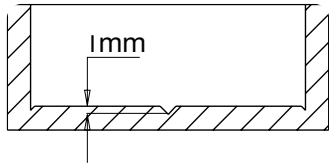
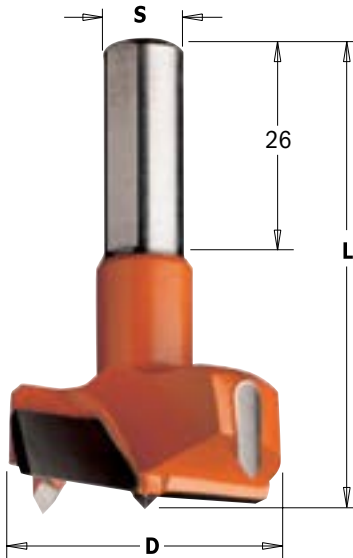

با ساختاری جدید  
با ۱ میل نقطه نفوذ مرکزی

317

قطر	طول	شفت	کد سفارش راست‌گرد	کد سفارش چپ‌گرد
D mm	L mm	S mm	ORDER NO Right-hand rotation	ORDER NO Left-hand rotation
15	57,5	10x26	317.150.11	317.150.12
20	57,5	10x26	317.200.11	317.200.12
25	57,5	10x26	317.250.11	317.250.12
30	57,5	10x26	317.300.11	317.300.12
35	57,5	10x26	317.350.11	317.350.12

369

قطر	طول	شفت	کد سفارش راست‌گرد	کد سفارش چپ‌گرد
D mm	L mm	S mm	ORDER NO Right-hand rotation	ORDER NO Left-hand rotation
15	70	10x26	369.150.11	369.150.12

370

قطر	طول	شفت	کد سفارش راست‌گرد	کد سفارش چپ‌گرد
D mm	L mm	S mm	ORDER NO Right-hand rotation	ORDER NO Left-hand rotation
35	77	10x30	370.350.11	370.350.12

517

پک متها نیش‌دار

Brad Point Bit Sets



تعداد	قطر	کد سفارش راست‌گرد
Description	Bit Diameter	ORDER NO Right-hand rotation
8-Pcs. SP Brad Point Set	(Ø3-4-5-6-7-8-9-10mm)	517.002.00



#### 4. Industrial Dowel Drills

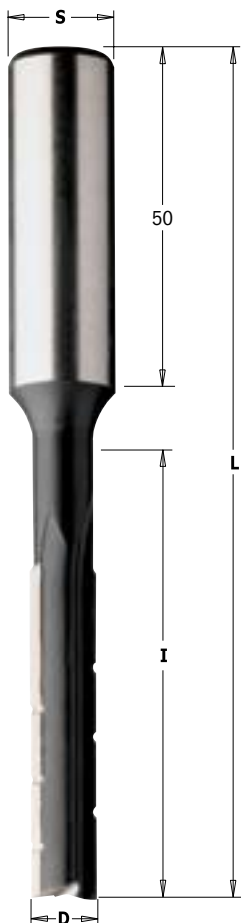

102

مته کومکن

Slot Mortising Bits with Chip-Breaker



قطر	کارگیر	طول	شفت	کد سفارش راست گرد	کد سفارش چپ گرد
D mm	l mm	L mm	S mm	ORDER NO Right-hand rotation	ORDER NO Left-hand rotation
16	100	155	16	102.160.31	102.160.32
17	105	160	16	102.170.31	102.170.32
18	110	165	16	102.180.31	102.180.32

102

کیت مته کوم

6-Piece Mortising Bit Sets



قطر	شفت	کد سفارش راست گرد	کد سفارش چپ گرد
D mm	S mm	ORDER NO Right-hand rotation	ORDER NO Left-hand rotation
6-8-10-12-14-16	16	102.001.00	102.001.10



## 529

مته گره درار

Plug Cutters



قطر درونی	قطر بیرونی	طول	شفت	تعداد دندانه	کد سفارش
d mm	D mm	L mm	S mm	Z	ORDER NO
30	42	140	13	5	529.300.31
35	47	160	16	6	529.350.31

## 541

نشان مته

Brad Point Bit Sets

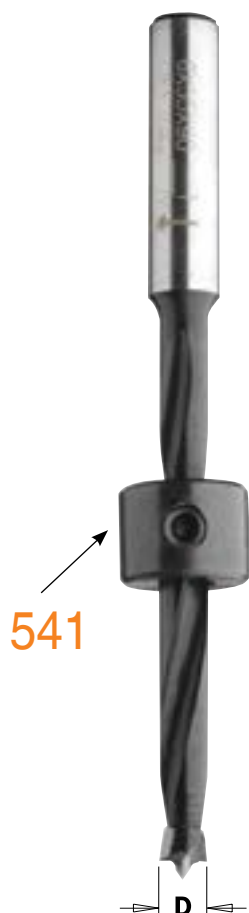
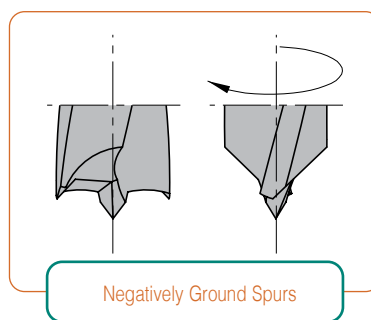

541

قطر	کد سفارش	متعلقات	
D mm	ORDER NO		
5	541.050.00	990.002.00	991.062.00
6	541.060.00	990.002.00	991.062.00
8	541.080.00	990.002.00	991.062.00
10	541.100.00	990.002.00	991.062.00
12	541.120.00	990.002.00	991.062.00



## تیغ آره عمودبُر

### Jig Saw Blades

۸۵	آره عمودبُر MDF بُر ساده
۸۵	آره عمودبُر لترون بُر
۸۵	آره عمودبُر MDF بُر بلند
۸۶	آره عمودبُر چوب بُر
۸۶	آره عمودبُر چوب بُر بلند
۸۶	آره عمودبُر چوب بُر باریک
۸۷	آره عمودبُر آهن بُر باریک
۸۷	آره عمودبُر آهن بُر ساده
۸۷	آره عمودبُر آهن و آلومینیوم





آره عمودبُر MDF بَر ساده

Jig Saw Blades

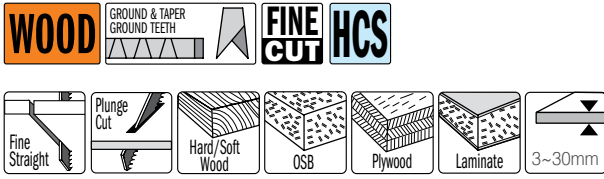

تعداد در هر بسته	کارگیر	طول کلی	شفت	تعداد دندان در اینچ	کد سفارش
Pack Quantity	I mm	L mm	TS mm	TPI mm	ORDER NO
5	75	100	2,5	10	JT101B-5



آره عمودبُر لرون بَر

Jig Saw Blades

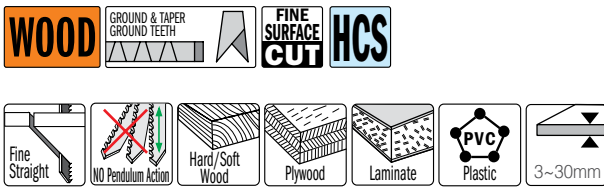

تعداد در هر بسته	کارگیر	طول کلی	شفت	تعداد دندان در اینچ	کد سفارش
Pack Quantity	I mm	L mm	TS mm	TPI mm	ORDER NO
5	75	100	2,5	10	JT101BR-5



آره عمودبُر MDF بَر بلند

Jig Saw Blades

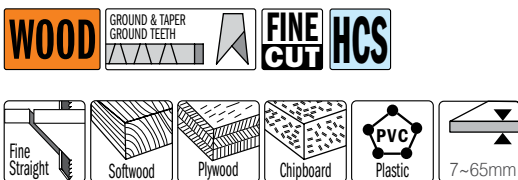

تعداد در هر بسته	کارگیر	طول کلی	طول تیغه	تعداد دندان در اینچ	کد سفارش
Pack Quantity	I mm	L mm	TS mm	TPI mm	ORDER NO
5	90	116	3	8	JT301CD-5

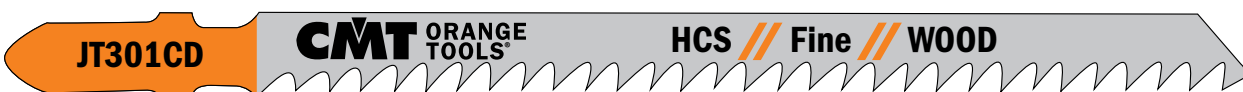



## 5. Jig Saw Blades

### آره عمودبُر چوببُر

Jig Saw Blades

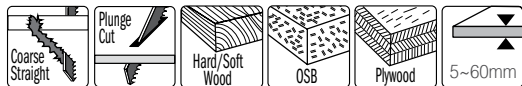
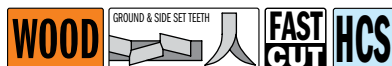

تعداد در هر بسته	کارگیر	طول کلی	طول تیغه	تعداد دندان در اینچ	کد سفارش
Pack Quantity	I mm	L mm	TS mm	TPI mm	ORDER NO
5	75	100	4	6	JT144D-5



### آره عمودبُر چوببُر بلند

Jig Saw Blades

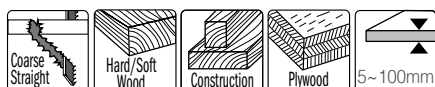
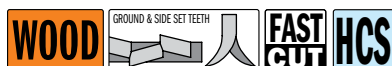

تعداد در هر بسته	کارگیر	طول کلی	طول تیغه	تعداد دندان در اینچ	کد سفارش
Pack Quantity	I mm	L mm	TS mm	TPI mm	ORDER NO
5	110	132	4	6	JT344D-5



### آره عمودبُر چوببُر باریک

Jig Saw Blades

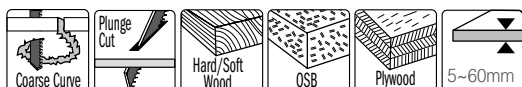
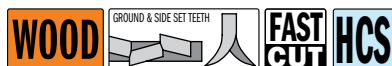

تعداد در هر بسته	کارگیر	طول کلی	طول تیغه	تعداد دندان در اینچ	کد سفارش راست گرد
Pack Quantity	I mm	L mm	TS mm	TPI mm	ORDER NO T Shank
5	75	100	4	6	JT244D-5



آره عمودبُر آهن بَر باریک  
Jig Saw Blades

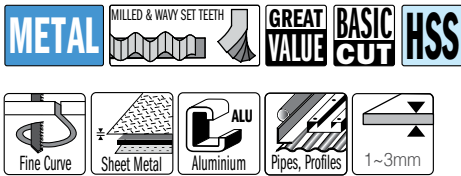

تعداد در هر بسته	کارگیر	طول کلی	طول تیغه	تعداد دندان در ۱ اینچ	کد سفارش
Pack Quantity	I mm	L mm	TS mm	TPI mm	ORDER NO
5	50	76	1,2	21	JT218A-5



آره عمودبُر آهن بَر ساده  
Jig Saw Blades

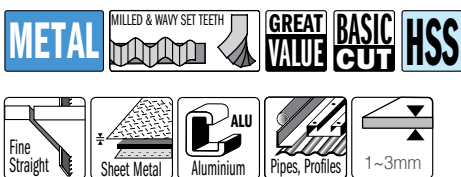

تعداد در هر بسته	کارگیر	طول کلی	طول تیغه	تعداد دندان در ۱ اینچ	کد سفارش
Pack Quantity	I mm	L mm	TS mm	TPI mm	ORDER NO
5	50	76	1,2	21	JT118A-5



آره عمودبُر آهن و آلومینیوم  
Jig Saw Blades

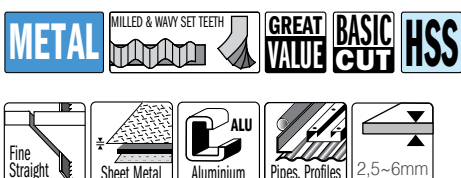

تعداد در هر بسته	کارگیر	طول کلی	طول تیغه	تعداد دندان در ۱ اینچ	کد سفارش راست گرد
Pack Quantity	I mm	L mm	TS mm	TPI mm	ORDER NO
5	76	50	2	12	JT118B-5



٤

## ابزارآلات برقی

Power Tools

٨٩

اُورِفرز مُشتی

٩٥

اُورِفرز دو دسته



CMT10

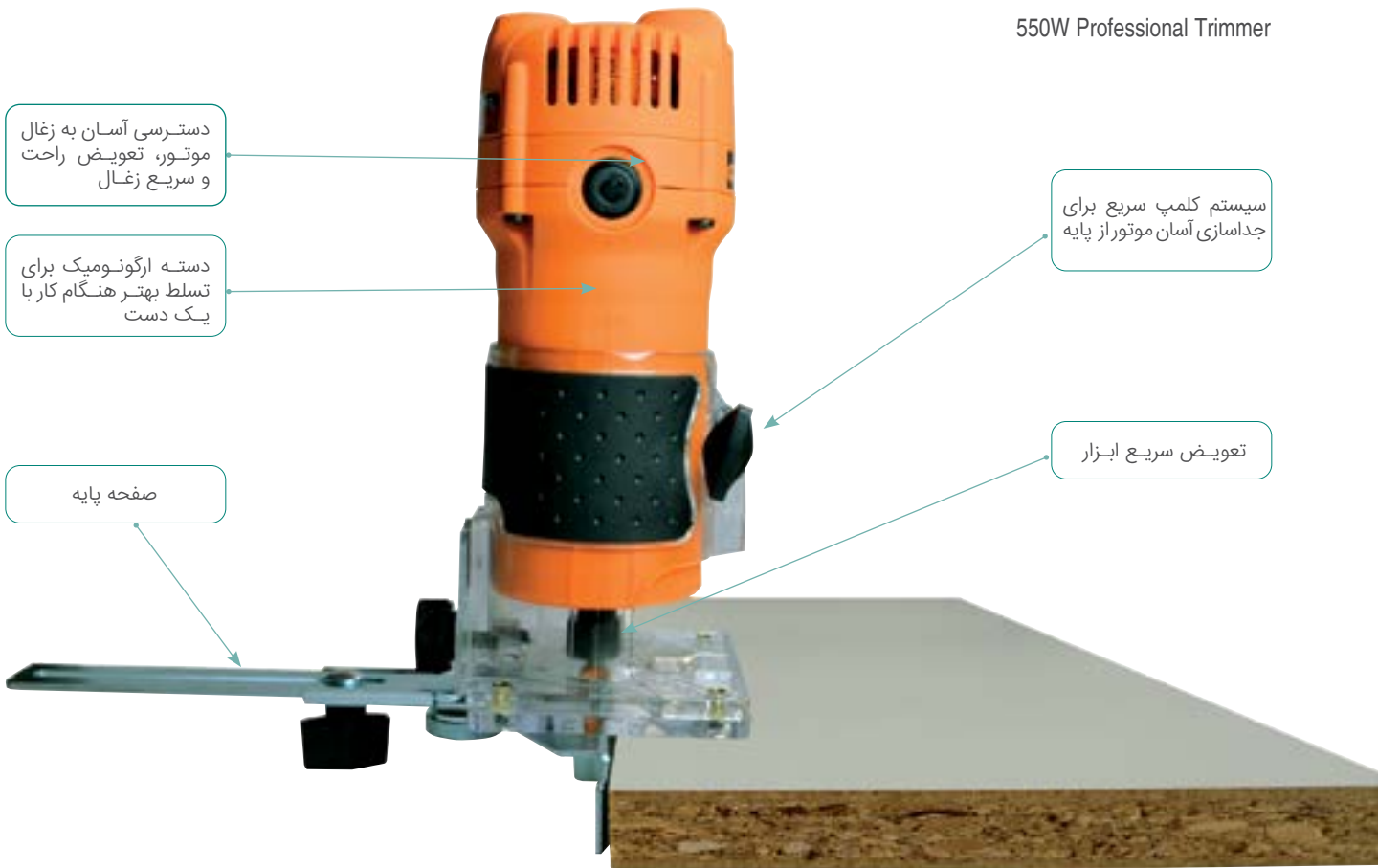

خطکش آلومینیومی برای تنظیم دقیق عمق فرزکاری به میزان دلخواه

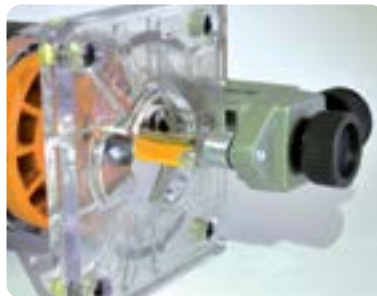

راهنمای برش با غلتک برای جلوگیری از ایجاد رد روی کار



تنظیم دقیق عمق



تجهیزات استاندارد



محافظ گردوغبار و صفحه پایه CMT10-16A قطعات یدکی



CMT10-17 مهره کلمپ



CMT10-18 کولت Ø6mm  
CMT10-18A کولت Ø6,35mm  
CMT10-18B کولت Ø8mm



CMT10-30 یک جفت زغال کربنی

وزن	سایز کولت	بازه حرکتی تیغه	سرعت متغیر	قدرت	توضیحات	کد سفارش
Tool weight	Collet diameter	Plunge stroke	No load speed	Power	Description	ORDER NO
1,8 Kg	Ø6-8mm	0-24mm	32.000 RPM	550 Watt	اُورفرز مُشتی ۵۵۰ وات	CMT10



## 6. Power Tools

# CMT7E

اُورفرز دو دسته  
1010W Router

فنر پلانچ قابل تعویض برای تنظیم آسان تیغ اُورفرز برای قرارگیری روی میز کار



دسترسی آسان به زغال موتور، تعویض سریع زغال‌های قدیمی به آسانی

دارای قفل ایمنی برای جلوگیری از روشن شدن ناگهانی دستگاه هنگام تعویض تیغ اُورفرز

دارای هواکش در کنار، دستگاه کاهش میزان ورود گرد و غبار به داخل دستگاه هنگام قرارگیری روی میز اُورفرز به صورت برعکس



دارای شاخص اندازه‌گیری سه مرحله‌ای و مجهز به صفحه اندازه با مقیاس میلی‌متری برای تنظیم میزان عمق برش

تنظیم ارتفاع بالای میز از طریق دسته چرخان با توجه به راهنمای داخل کیت



لوله مکش غبار یک سال گارانتی تجهیزات استاندارد دارای دفترچه راهنما آچار برای تعویض آسان تیغه خدمات تکنیکی در سرتاسر دنیا کولت در سایزهای ۸ و ۱۲ میلی‌متر پایه با قابلیت تغییر سایز و فنس قابل تنظیم

دارای سیستم کنترل سرعت و شروع آرام (Soft Start) از ۸۰۰۰ تا ۲۰۰۰۰ دور بر دقیقه



تغییر حالت از اُورفرز پلانچ به اُورفرز ثابت با استفاده از یک دکمه

دارای محافظ کاملاً بسته ایجاد ایمنی کامل در محدوده برش

دارای فنس چندکاره برای کنترل بهتر هنگام استفاده به صورت دستی و برش گرد

دارای پین‌های مخصوص برای نصب سریع و جداسازی فنس از دستگاه



وزن	سایز کولت	بازه حرکتی تیغه	سرعت متغیر	ورودی	قدرت	توضیحات	کد سفارش
Tool weight	Collet diameter	Plunge stroke	No load speed	Input	Power	Description	ORDER NO
6 Kg	68-0 mm	0-59 mm	8.000-20.000RPM	2400 watt	1 KW	اُورفرز دو دسته	CMT7E

# Y

## متعلقات و دیگر محصولات

### Accessories

۹۲	میز اُرفرز معمولی
۹۳	میز اُرفرز حرفه‌ای
۹۳	شابلون میز اُرفرز MDF
۹۴	زاویه سنج دیجیتالی
۹۴	زاویه سنج دیجیتالی تاشو
۹۵	مکنده توربو
۹۶	اره سناده
۹۶	شابلون
۹۷	کولت دستگاه الیت
۹۷	تبدیل شفت تیغ فرز
۹۸	کلمپ ISO 30
۹۸	رابط فرز زمینی
۹۸	کولت ER32
۹۹	شابلون شیشه
۹۹	ست تیغ بند





999.110.00

میز اُورفرز معمولی  
New Professional Router Table

توضیحات	کد سفارش
Description	ORDER NO
میز اُورفرز معمولی	999.110.00







999.500.01

میز اُورفرز حرفه‌ای  
Industrio Routing System

توضیحات	کد سفارش
Description	ORDER NO
میز اُورفرز حرفه‌ای	999.500.01
گیج مخصوص اُورفرز	999.501.08



گیج میز اُورفرز MDF

999.501.07

شابلون میز اُورفرز MDF  
Industrio Routing System



توضیحات	کد سفارش
Description	ORDER NO
شابلون میز اُورفرز MDF	999.501.07



## 7. Accessories

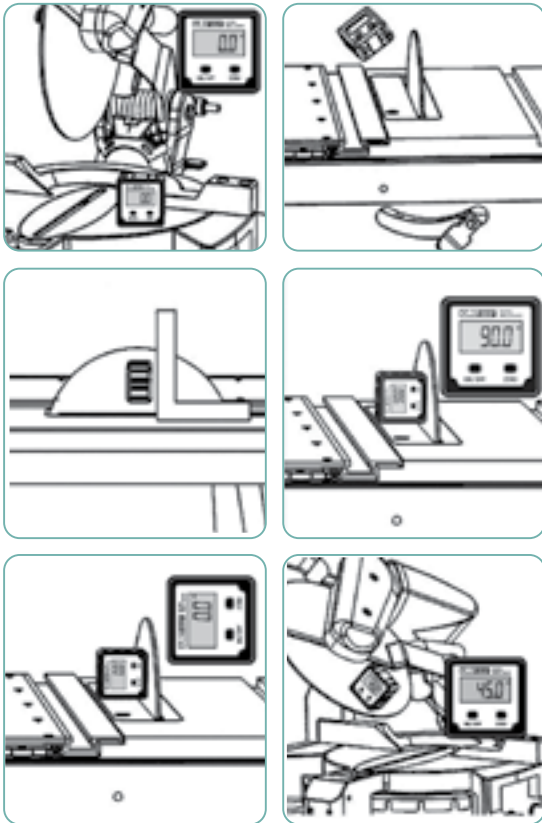

### DA6-001

زاویه سنج دیجیتالی  
Digital Angle Gauge



توضیحات

کد سفارش

Description

ORDER NO

زاویه سنج دیجیتالی

DAG-001

### DAF-001

زاویه سنج دیجیتالی تاشو  
Digital Angle Finder



دارای ۴ حفره برای ثابت ماندن هنگام اندازه‌گیری زوایای خاص؛ با باز کردن پیچ قفل زوایای مختلف تا ۳۶۰° را اندازه بگیرید

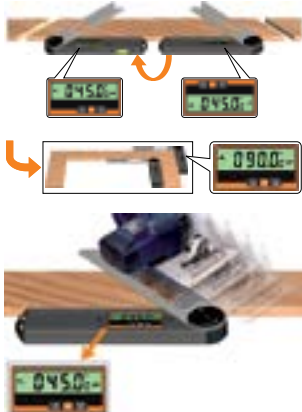

توضیحات

کد سفارش

Description

ORDER NO

زاویه سنج دیجیتالی تاشو

DAF-001

تیغه متحرک را برای افزایش دقت برش و علامت‌گذاری در زاویه مورد نظر ثابت کنید



مکنده توربو

Kinetic Dust Extractor

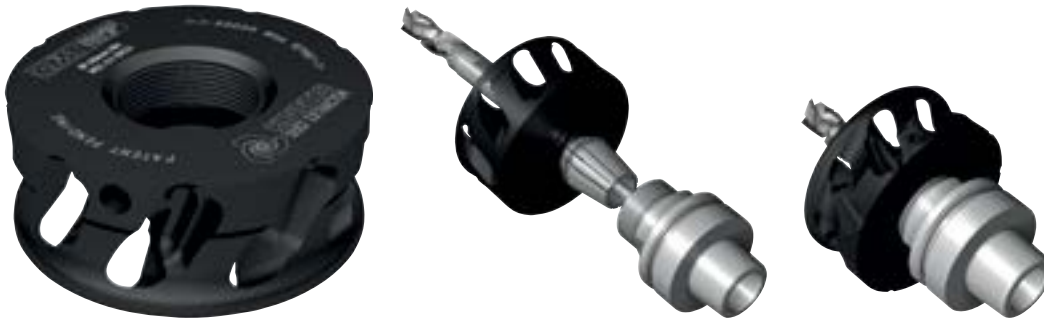

استفاده آسان:

- به عنوان مهره کلمپ نصب و جدا شود
- تهویه بهتر
- افزایش ایمنی
- عملکرد ابزار و کیفیت برش
- انجام فرایند بدون اتلاف زمان
- مناسب برای فرزکاری و جانمایی
- جایگزینی مناسب برای مهره کلمپ استاندارد
- افزایش عمر دستگاه و کاهش هزینه‌های نیروی کار
- مناسب برای نوع گیره فشنگی با تیغ آورفرز استاندارد
- مناسب برای چوب، چوب روکش‌دار، MDF، کورین، گچ
- کارایی قابل قبول حتی با دور موتور کم: از ۶۰۰۰ تا ۲۰۰۰۰
- روکش سرامیکی ضخیم با خاصیت ضدخورده شدگی، ضدفرسایش و آلیاژ سبک برای بدنه دستگاه

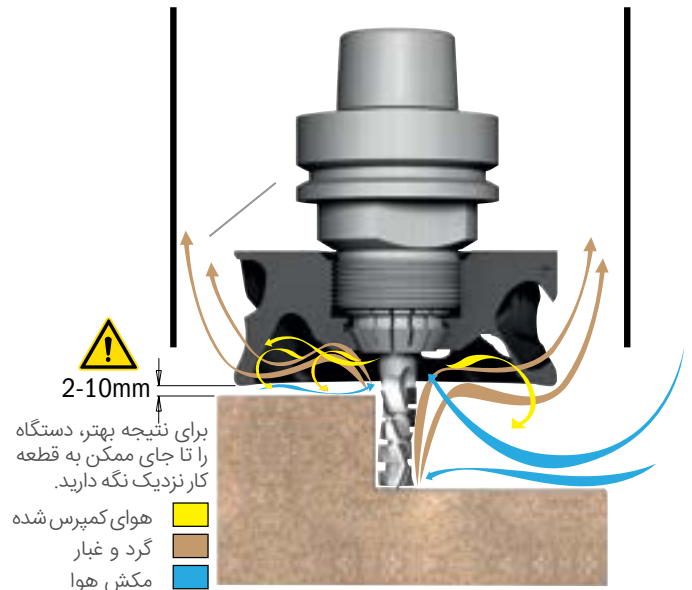

توضیحات	قطر	کد سفارش
Description	D mm	ORDER NO
مخزن مکش گرد و غبار کینتیک برای گیره با کولت‌های ER۳۲	100	992.101.ER32

کار بدون مخزن مکش غبار کینتیک



کار با مخزن مکش غبار کینتیک





299.11

اره سنباده  
Calibration & Sanding Disks



قطر	شفت	ضخامت بدنه	کد سفارش
D mm	B mm	P mm	ORDER NO
200	30	2,8	299.111.00M
250	30	2,8	299.112.00M

شفت	طول	کد سفارش
Description	L mm	ORDER NO
شابلون ۱۲ در ۱۲ میلی متری	1200	TMP-1200

شابلون

Flexible Templates for Curved & Arched Routing



قالب مناسب فرم های منحنی یا قوس دار



360

کولت دستگاه الیت

Adaptors



مناسب برای دستگاه  
Masterwood-Maggi - Griggio

ارتفاع کلی	قطر داخلی	قطر بیرونی	قطر کلی	کد سفارش	متعلقات	
L mm	B mm	d mm	D mm	ORDER NO		
40	10	19,5	20	360.301.00	990.015.00	991.062.00



990

کولت دستگاه الیت

Adaptors



مناسب برای دستگاه : Vitap

ارتفاع کلی	کارگیر	قطر داخلی	قطر کلی	کد سفارش	متعلقات	
L mm	B mm	d mm	D mm	ORDER NO		
42	10	17,5	18	360.101.00	990.015.00	991.062.00

799

تبدیل شفت تیغ فرز

Bushings

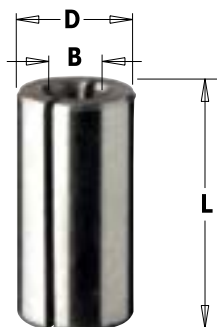

قطر داخلی	قطر کلی	ارتفاع کلی	کد سفارش
B mm	D mm	L mm	ORDER NO
6	8	25	799.060.00
8	12	25	799.380.00
6	12	25	799.260.00

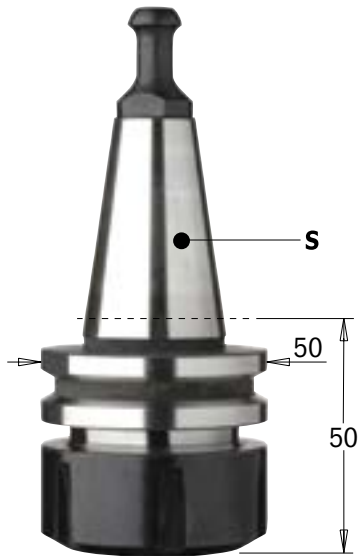

183.200

کلمپ ISO 30

ISO30 Chucks for "ER32" Precision Collets



995.200

مدل	کولت مناسب	بازه نگهدارنده	کد سفارش راست گرد
S	To be used with collet	Retaining stud mm	ORDER NO
ISO 30	ER32	∅ 12-8	183.200.02

796

رابط فرز زمینی

Chucks &amp; "ER20" Collets for Spindle Moulder Machine

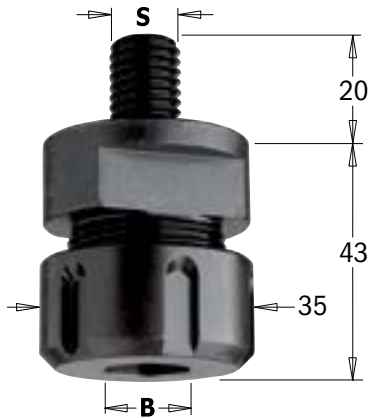

شفت	قطر داخلی	طول مفید	کد سفارش
S mm	B mm	L mm	ORDER NO
M16x2	3 ~ 12,7	43	796.162.00



184-ER32

کولت ER32

Precision Collets "DIN6499"

قطر داخلی	کد سفارش
B mm	ORDER NO
12	184.120.00
6	184.060.00
8	184.080.00



## TMP-R12

شابلون شیشه

12 Corner Radius Router Template Set from 3mm to 25mm

توضیحات	کد سفارش
Description	ORDER NO
شامل: ۱۲ عدد الگوی گوشه ۴ عدد پین تراز ۴ عدد پیچ چوب	TMP-R12

### شعاع انحنا

mm	inches
3	1/8"
5	3/16"
6	1/4"
8	5/16"
10	3/8"
11	7/16"
12	1/2"
14	9/16"
16	5/8"
19	3/4"
22	7/8"
25	1"

ست ۳ عددی شابلون شیشه‌ای دارای شابلون ۸ میلی‌متری از جنس آلکلیریک برای برش ۱۲ شعاع مختلف (با هر شابلون ۴ عدد) با استفاده از تیغ پرداخت و تیغ پروفیل (جداگانه خریداری شود) دارای ۴ عدد پین تراز و ۴ عدد پیچ چوب. از پین‌های تراز برای تنظیم شابلون و از پیچ‌ها برای ثابت کردن آن استفاده کنید. سپس پین‌ها را بردارید و با استفاده از تیغ اُرفرز گوشه‌ها را با شابلون‌ها برش بزنید.

## CMT 192

ست تیغ بند

Set of 2 Magnetic Knife Setting Jigs

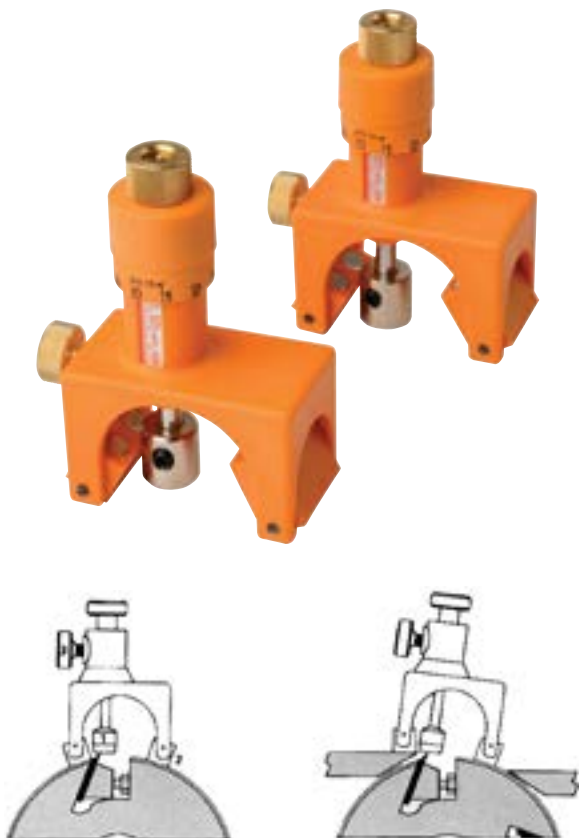

توضیحات	کد سفارش
Description	ORDER NO
ست تیغ بند	CMT792



#### ساختمان مرکز شهر:

تهران | خیابان کارگر جنوبی | پایین تراز میدان حر | شماره ۹۳۱

#### نمایشگاه و فروشگاه دائمی تهران:

اتوبان آزادگان | به سمت جنوب | بعد از اتوبان فتح  
احمدآباد مستوفی میدان دکتر پارسا  
شهرک بهسازی صنایع چوب ایران | سالن ۲۷

تلفن های تماس: ۰۲۱ - ۶۷۹۲۱۰۰۰ | ۰۲۱ - ۶۲۷۲۱

 [www.sazokar.com](http://www.sazokar.com)

 [cmt.sazokar](https://www.instagram.com/cmt.sazokar)

Version 2022

